

# HeatWorks

HeatWorks 15 | November 2015 | [www.ceramicx.com](http://www.ceramicx.com)

## WAKE UP TO COST REDUCTION

Consultant David Russell on  
thermoforming energy savings

**CIRCLE** Create  
InfraRed Characterisation  
Laboratory Equipment

## HOW BIG IS BIG ?

One of the largest shuttle  
thermoforming machine  
systems in North America

2020

## HORIZON 20-20

Ceramicx joins Euro project  
for medical products.

## HELPING FORM THE PERFECT SHEET

THE HERSCHEL TEST  
MACHINE MAPS  
THE INVISIBLE  
INFRARED  
HEAT SPECTRUM



Friedrichshafen | Germany  
**FAKUMA 2015**



Steady to Better  
**U.S. THERMOFORMING MARKET**



Siteges | Spain  
**NPE** EUROPEAN THERMOFORMING CONFERENCE



## Partnerships, projects, people.....

Welcome to the fifteenth edition of our HeatWorks magazine. It has been a little while since I referenced the value of partnerships – in life, in business – and I make no bones about doing so again.

Indeed I would go so far as to suggest that much business success depends absolutely upon successful partnerships. In our case, last month saw us hosting Weco, our USA distributor and their customers here at the Ceramicx factory. It was an invaluable time; for business strategy, for creative thinking, for consolidating relationships and, not least, for generating purchase orders.

In the same month we travelled to meet our German distributors, Friedr Freek, in their place of business and, from there, visited the Composite Europe exhibition, Stuttgart, together.

One mark of true partnership lies in exploring new horizons together. Ceramicx is delighted to be travelling the composite materials technology road in tandem with our leading associates and partners. For its part, Freek has arranged for Ceramicx products to show at the Fakuma 2015 exhibition – close by the new thermoforming feature at the show. A good partnership involves reciprocity and clear and mutual self interest.

In fact, on more or less every page of this magazine issue you will see committed individuals and companies all working a common cause together with Ceramicx. There is Hasan Duman, manager of newly formed Ceramicx Turkey reporting on recent business trends in Turkey. There is Dr Garret O'Donnell outlining the exciting things to come from our new CIRCLE project with Trinity College Dublin. There is David Russell, fresh with messages on energy-saving from the Plastics Design and Moulding (PDM) conference in Telford, UK. There is the launch of joint Intertrade activity and the Fusion project with Belfast Metropolitan College.

And there is also, not least, the new work being done by our new and expert recruits in materials and aeronautic technology. Ceramicx is fast becoming a very high-intensive, knowledge-based hub for many emerging IR heat technologies. Peter and Angel will be a key part of it and have made a great start with their work.

If you are reading this, may I suggest that you do not hesitate in getting in touch with us to discuss any part of your work in IR heat technology.

It is clear that applications for this technology cannot but grow and expand. Ceramicx cannot always go it alone. Indeed we need our people and our partnerships to help us ride the coming wave.

I look forward to hearing from you.



Frank Wilson  
Managing Director, Ceramicx Ltd.

## Contents

- Page 1 The Herschel  
*Helping form the perfect sheet.*
- Page 4 The American market is on the up. Ceramicx and its American partner Weco.
- Page 6 So how big is big? One of the largest shuttle thermoforming machine systems in North America.
- Page 7 Steady to better. The U.S. thermoforming market.
- Page 8 Create a Circle. Enhanced product testing and validation.
- Page 10 Horizon 20-20. Ceramicx joins Euro project for medical products.
- Page 11 SPE Sitges hosts the 10th European Thermoforming Conference
- Page 12 The cure. Developing methods of curing composite materials.
- Page 13 Wake up to cost reduction. Consultant David Russell on thermoforming energy savings.
- Page 14 Fakuma 2015. Ceramicx and its distributor partner Friedr Freek at the Fakuma plastics exhibition.
- Page 15 Putting the heat on composites
- Page 16 Turkey Discover the potential.
- Page 17 Snap shot Introducing Peter Marshall and Angel Michealraj.
- Page 18 - 23 Ceramicx Product Range
- Page 24 Ceramicx News
- Page 24 The Ceramicx Team  
*Talk to us today about your infrared needs*

## HeatWorks

Publication manager	Cáthál Wilson <a href="mailto:cathal.wilson@ceramicx.co.uk">cathal.wilson@ceramicx.co.uk</a>
Editorial	Adrian Lunney <a href="mailto:adrian@adrianlunneypr.com">adrian@adrianlunneypr.com</a>
Design and Production	David Hayward <a href="mailto:david.hayward@ceramicx.com">david.hayward@ceramicx.com</a>
Distribution	Amanda Murphy <a href="mailto:amanda.murphy@ceramicx.com">amanda.murphy@ceramicx.com</a>
Published by	Ceramicx Ltd. <a href="mailto:sales@ceramicx.com">sales@ceramicx.com</a>

Are your contact details correct?

If not or you no longer wish to receive HeatWorks please email [amanda.murphy@ceramicx.com](mailto:amanda.murphy@ceramicx.com)

# *Herschel earns its spurs*

## *- Helping form the perfect sheet*

HeatWorks readers will know that earlier this year, Ceramicx Ltd together with Trinity College Dublin (TCD) signed a technology licensing agreement to build and market a test instrument to map the previously invisible IR heat spectrum.

### **HeatWorks magazine takes stock of the advances made since then...**

Weco International - Ceramicx's US distributor - is the first sales channel for the new machine and immediately after the TCD agreement, the machine was christened "The Herschel" and went on show at the triennial exhibition for the US plastics industry, NPE 2015, Orlando Florida. Reason? The Herschel has immediate benefits to offer the world of plastics thermoforming – both for inline and cut sheet production.

The Ceramicx Herschel is a scientific tool for characterizing the infrared heat flux spatial distribution in three dimensional spaces. To date it is the only machine of its kind in the world to offer this service.

Large US inline thermoforming customers and OEM manufacturers have been shown how the Herschel creates 3D maps of the Infrared heat radiation. US thermoforming machinery builders such as Modern Machine were shown how the Herschel can dispense with the black art of thermal estimation and instead introduce pinpoint accuracy in machine design, based upon the true and actual heat needs of any plastics thermoforming system.

The Herschel utilizes a robotic arm, linear stages, control and acquisition software and infrared heat flux sensors along with other instruments to map the IR heat flux distribution in any system. Sensors, robotics; thermocouples, data acquisition and mathematical analysis software all work together in providing figures that give the thermoformer – and the designer of any industrial system – the wherewithal to optimize the energy demands in the system.

These figures can be tweaked further; taking into account the precise nature of the effect of IR heat radiation on a variety of target bodies - including all varieties of polymer sheet. All of these have different properties and performance characteristics when subjected to different kinds of IR heat radiation; short, medium and long wavelength.

Ceramicx founder and director Frank Wilson says that 'our new Herschel takes the thermo out of thermoforming and puts it under the microscope: It analyses the heat work component in any system so that all outputs and manufacturing decisions may be appropriately measured, predicted and supported. The practical result of this work is that thermoforming companies may design and lower their energy needs with confidence, thereby cutting the carbon footprint of all products made.'

In addition Ceramicx is able to use the Herschel to design and create ever more bespoke IR heating systems for the needs of different thermoforming companies. The company is also able to use the Herschel to measure and compare the performance of competitor heating systems.

The small size of the sensor and the accurate positioning of the robot allow excellent resolution when it comes to heat flux mapping of industrial scale equipment and facilitates the measurement of everything from the energy efficiency of heaters to the amount of energy that would reach a target in real application.

Empirical IR heat measurement is key to progress in thermoforming. 'In the past, for example, there was no reliable way of knowing the IR heat distribution from arrays of heaters for thermoforming, since you could not 'see' the heat. Now, we can use the Herschel to see the IR heat and how it spreads in 3D



*The heart of The Herschel is a Schmidt-Boelter radiant heat flux sensor. This specialized sensor uses IR transparent glass, specialized material and temperature sensor systems to measure the IR heat impinging upon a target that is less than 1 millimeter in size.*



space. This has opened up a whole new world in terms of our understanding of IR heating systems and how to properly design them for specific targets.'

He adds that 'there are actually no limits to these targets; all manner of polymer-based products from vending cups to sports shoes; composites; glass; automobile brake discs; printing; textiles; food - the Herschel can be deployed anywhere where predictive IR heat measurement and heat design is needed.'

The test was conducted using the sandwich tester as shown in the picture.

The sandwich tester is an advanced material thermal response testing machine. Various type of infrared emitters can be mounted at two positions, facing vertically up and down. This ensures that the tested material can be heated from the top and/or the bottom. Four non-contact optical pyrometers were used to determine the top and bottom surface temperature of the tested material. The emitters

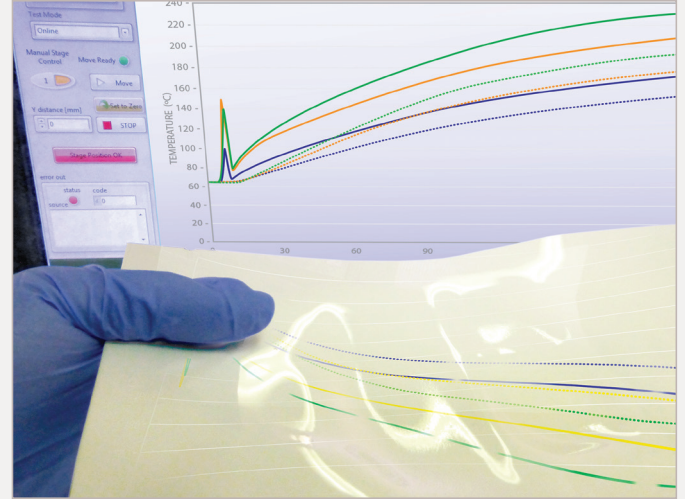

*The Herschel software programs have been written to generate 3d images having facilitated the positioning of the heat flux sensor anywhere and in any position in front of heaters and heater assemblies*

The revived North American manufacturing sector is now currently leading the uptake for many of these scenarios – not only in thermoforming platen design and build, but also in terms of heat analysis and test work for OEM and blue chip brand manufacturers.

Some of the savviest OEMs – in automotive, packaging, sports goods - are very interested indeed in getting IR heat testing into their process and in looking at the heat performance of various kinds of thermoformed polymer sheet. Depending on the application and need, some thermoforming polymer sheets are a better fit-for-purpose than others. Others still may offer more cost-effective use when matched with the right heat sources.

The Herschel is able to empirically test and rate the alternatives one against each other – providing thermoforming manufacturers with a scientific rationale for decision making.

And not only can the Herschel determine the heat performance of different grades and thickness of polymer sheet – tested one against another – it can also assess the performance of different kinds of IR heater when applied to a single material specification. In other words, the material under test stays the same – the quality of IR heat and heater is changed.

A recent experiment at Ceramicx, for example, saw a programme of testing a polyurethane TPU sheet material coated with an EVOH barrier layer. The client wished to understand the performance of the material under different kinds of IR heater – and the Herschel was able to oblige.

The experiment was designed and structured around the Herschel and a Ceramicx designed 'sandwich tester'.

are allowed to warm up to their operating temperature and the material is then brought under the emitter(s) for a predetermined period of time.

In the first material test the transparent material sample was tested using four types of Ceramicx IR emitters, ceramic emitter (FTE 1000W), quartz medium emitter (FQE 1000W), quartz halogen tube emitter (QHM 1000W) and black hollow ceramic emitter (black FFEH 1000W) respectively.

The material was not preheated and was heated from a top emitter only. The target temperature at the bottom surface of the material was set to be 200°C.

All tests were conducted for a maximum of 150 seconds. There were two emitter types that can achieve the target temperature of 200°C (392°F) at the top and bottom surface within the time constraint.

The quartz medium emitter (FQE 1000W) was the best performing out of the four types of IR emitter. It heated up the bottom surface of the material to 200°C after 130 seconds.

The black hollow ceramic emitter (black FFEH 1000W) came second in terms of performance. It was able to heat the bottom surface of this material to the target temperature after 142 seconds.

The ceramic emitter (FTE 1000W) came third in terms of performance. It cannot heat the bottom surface to the target temperature within the predetermined time period. The final temperature achieved was 187°C after 150 seconds test.

The quartz halogen tube emitter (QHM 1000W) was the worst performer of the four types of emitter employed for these tests. The bottom surface cannot be heated to the target temperature, neither as the top surface.



The results show that the test material in this particular case absorbs medium and long wavelength infrared radiation better than short wavelength infrared radiation. It's important to note that other materials and polymeric formulations would behave differently. It's simply that for this particular material these IR emitters are ranked in this way.

The quartz medium emitter works particularly well with the material having a specific thickness of 1.95mm. The black hollow ceramic emitter has also demonstrated its effectiveness in heating this material. However, it takes 12 seconds longer than the quartz medium emitter to achieve the target temperature at the bottom surface. The improved efficiency of the black hollow ceramic emitter leads to a better performance in comparison with the standard ceramic emitter.

There is also an approximate 15°C in difference between using the standard ceramic emitter and the best-performing quartz medium emitter at when the quartz medium emitter heated the material to the target temperature

(130 seconds). The quartz halogen tube emitter performs the worst of all the IR emitters tested. The bottom surface temperature reached at the end of the test using a quartz halogen tube emitter is approximate 8°C lower than using a quartz medium. This represents a significant deficiency in terms of heating performance.

In any kind of plastics thermoforming the question of pre-heating the sheet (whether cut or inline must be considered). A test programme of pre-heating was therefore organised in relation to this material and the performance of the four IR emitters.

(Figure 10) shows that the preheating process helps the bottom surface achieve the target temperature quicker than without applying the process. It takes 124 seconds for the preheated material to reach the target temperature. This represents an improved 6 seconds (4.6%) in cycle time on this A4 size material sample, rather than 130 seconds required to achieve the same temperature without applying the preheating process.

The size of the actual heated material could be significantly larger than the tested sample. The distance between the emitter and the heated material could also be larger than 100mm, the optimal heating distance, which was used for all tests demonstrated.

Therefore, the heating period required is also likely to be longer, this 4.6% in cycle time saving can be transferred into a more significant reduction in energy consumption, and thereafter cost saving. For an example, a platen might be built with 200 pieces of quartz medium emitters (FQE 1000W) installed for heating this material.

The normal operation time (without preheating) is assumed to be 10 hours per day. If a 4.6% in cycle time saving is taken when the preheating process is conducted, this can result in a total yearly energy saving of some 23,920kWh. The savings can therefore be substantial. Figure 11 shows the preheating process also contributes an improved temperature cycle time using a black hollow ceramic emitter. It is also approximately 7 seconds (4.9%) faster for the bottom surface of the preheated material sample to reach the target temperature than the non-preheated material sample.

All in all the TPU coated material was tested by Ceramicx and the Herschel through three scenarios:

**FQE 1,000W and FFEH 1,000W SINGLE SIDED HEATING TEST - PRE HEATING V's NO PRE HEATING**

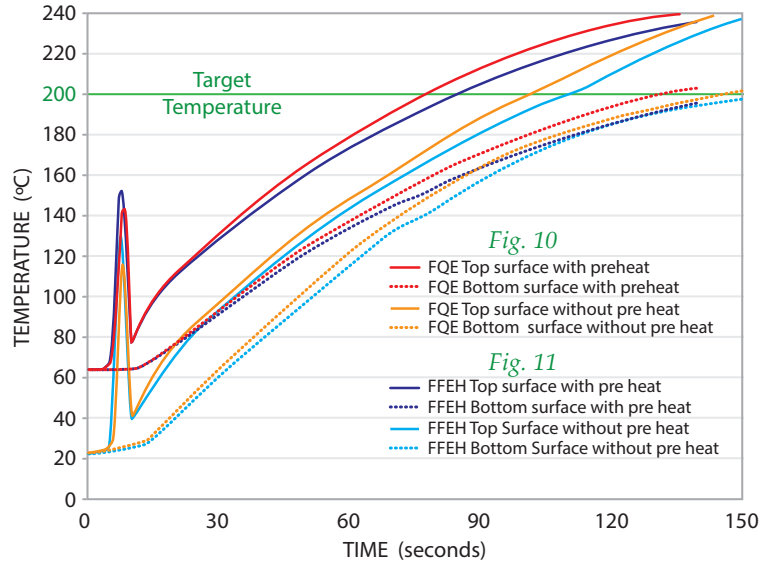

Fig 10 - Heating test using medium wave quartz emitter FQE 1000W.

Fig 11 - Heating test using long wave black hollow ceramic emitter FFEH 1000W

The material was heated to the target temperature (200°C, 392°F) from the ambient temperature (approximate 22°C, 72°F) using four types of Ceramicx IR emitters, ceramic emitter (FTE 1000W), quartz medium emitter (FQE 1000W), quartz halogen tube emitter (QHM 1000W) and black hollow ceramic emitter (black FFEH 1000W).

The material was preheated to 65°C (150°F) in a testing oven, and then heated to the same target temperature using the same four types of IR emitters.

The material was elevated for 30mm, therefore the heating distance was reduced from 100mm to 70mm. The tests were conducted using a quartz halogen tube emitter (QHM 1000W) only.

In the first two heating tests, the quartz medium emitter (FQE 1000W) and black hollow ceramic emitter (FFEH 1000W) were able to heat the bottom surface of the material in order to achieve the target temperature.

In the third test, despite the reduction in heating distance the quartz halogen emitter was unable to heat the bottom surface to the required target level.

In short, this set of experiments was able to empirically demonstrate the optimum parameters for thermoforming this material, including types and design of IR emitters; preheating conditions and typical heater distance from the target material.

As the 21st Century advances the applied science of IR heating will develop from a relative infancy to a more informed and mature outlook. IR-based heating is very often misunderstood and often misapplied in manufacturing. Comparing temperature with radiation, for example, is a very common mistake in industry.

The new Herschel instrument from Ceramicx is intended to help remedy many of these situations, can creative predictive production parameters that reduce cost and carbon footprint and that can also dispel many IR heating myths.

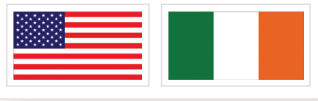

# *An American market upswing plus new heating applications*

The five months between NPE2015 in March and the SPE Thermoforming Conference at the start of September have seen a strong increase in business for Ceramicx and its American business partner Weco International.

**Yes, the two companies exhibited together at both events and experienced strong customer/prospect interest at both, which certainly helps fuel new sales, but other factors, such as emerging market sectors, also are contributing to rising sales activity.**

The traditional thermoforming market in the U.S., generally estimated to be about 85% packaging and 15% industrial, is healthy. In tune with a growing national economy, American thermoformers are seeing their business levels rising and consequently are running their equipment more. What came to the Ceramicx and Weco booths at both recent shows were thermoformers wanting to improve their processes through higher speed, quality, efficiency or all three to gain a market advantage. And that is precisely what Ceramicx infrared heating systems do so well and so economically.

Obviously process improvement can be achieved by adding new lines, and even though it's a major investment, many thermoformers are talking with Ceramicx/Weco about adding new lines. Yet at least as many are looking to upgrade existing systems, something that Frank Wilson, Managing Director of Ceramicx, and Brett Wehner, President of Weco International, consistently mention as a leading advantage of Ceramicx infrared process heating technology — a reasonably priced investment with immediate and ongoing improvements in product quality, line speed and energy efficiency.



*Tony, Brett and Brett from Weco on their recent trip to Ceramicx in Ireland*

Brett Terbrack, Technical Sales Specialist at Weco, says replacing older equipment accounts for a significant share of the current business increase. Although infrared is not new, processors increasingly are researching it and discovering its advantages, in particular the advantages of the newest generation of Ceramicx IR technology. He says many processors studying IR have discovered the Ceramic Infrared Training Centre on the Ceramicx website, and taken one or more of the four regularly updated online courses on IR technology and its application to industrial

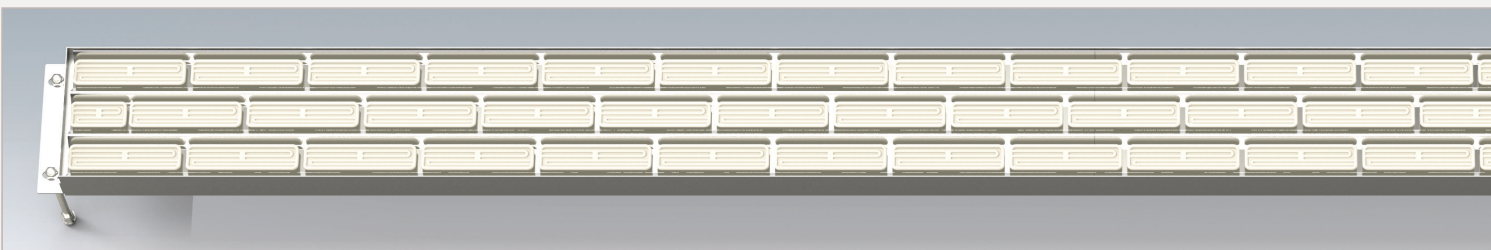

*35.1kW long wave ceramic platen (used in glass drying application)*





Left, 5.4kW height adjustable long wave oven (used for heating carbon fibre turbine blades) Infrared platens

Centre, 1.5kW bench top material test unit Right, 8kW bench top test unit with interchangeable

process. This connects them with Ceramicx and Weco International for when they want to discuss what they want to do with IR. (Ceramicx also conducts onsite training at its headquarters in Ireland.)

We mentioned emerging markets for Ceramicx/Weco, but let's again emphasize that they have plenty of business in traditional thermoforming markets. Custom thermoformers made up over 20 % of those visiting the companies' booth at the SPE Thermoforming Conference, and they were talking about real projects, as well old heating systems. One very active market for Ceramicx/Weco in the U.S. is food packaging; particularly thin-film made at high speeds, often involving new materials and multi-layer structures. Automotive Tier suppliers, which are also interested in IR technology and have become another active market for Ceramicx technology in the U.S. Terbrack says it seems as if every company making thinner-gauge, non-metal auto parts — interior components, car trunk/boot liners, skid plates, fender liners, grills — wants to improve its processes. The auto industry's extensive lightweighting efforts aimed at improving fuel efficiency are a driving force (pardon the pun) and for thermoformers that means processing thinner, yet stronger, film and sheet, running them at higher rates and holding top end-product quality. The precision that Ceramicx/Weco infrared technology provides in its heating technology and advanced controls supports consistent high quality output, and that resonates with these thermoformers. A heating system was recently supplied for the production of auto airbag covers using a new material. Another newly emerging source of business for Ceramicx/Weco is composites. Composites technology itself is emerging in end markets such as automotive, aerospace,

sustainable energy, building and construction and more. For Ceramicx/Weco, the composites business is in the early phases: mostly research, evaluation and testing. Composites are prized for their high strength-to-weight ratio, resistance to corrosion, design flexibility and enough other plus factors that we can expect to see a lot of them in the near future. Composites are competing for lightweighting applications in the automotive sector, and auto designers and manufacturing engineers are learning how to work with them. One thing is clear: Making carbon fibre reinforced panels and other parts rapidly at consistently high quality will need high-precision process heating.

**We're non-invasive when we enter a customer plant**

Ceramicx/Weco is on it. We asked Brett Terbrack what the key decision factor usually is for a company considering Ceramicx/Weco systems technology. He answered that it varies from customer to customer. For an experienced thermoformer replacing older technology, it is the Ceramicx combination of performance and efficiency, particularly energy efficiency, and the comprehensive approach of the two companies. A Ceramicx system is custom-fitted to the application by Ceramicx and Weco. For many customers new to IR technology, says Terbrack, the comprehensive approach almost always becomes the deciding factor.

Other companies will sell an oven that provides a certain temperature, but Ceramicx/Weco go much further: It considers the customer's line speeds, cycle times, facilities and other production details, then determines the right heaters, the correct IR wavelength, the number of zones, the type of control and every other detail needed to create a one-off, custom-tailored system. Terbrack says Ceramicx/Weco take a special pride in not disrupting a customer's production, particularly when upgrading an existing line. "We're non-invasive when we enter a customer plant," he says. "We improve the process and we don't cause any grief, which is what makes Ceramicx and Weco stand out from all other suppliers."

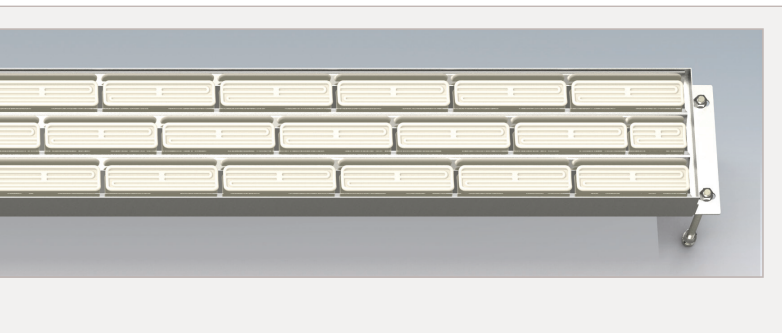



# *A very big machine gets the best IR heat*

The four men in the photo are standing in front of a Ceramicx heating oven that forms an integral part of one of the largest shuttle thermoforming machine systems in North America - possibly the largest.



From left to right they are: Vince Hicks and Corey Pohlman, partners in thermoforming machine manufacturer Modern Machinery of Beaverton, Michigan, Brett Wehner, President of Weco International, and Brett Terbrack, Technical Sales Specialist at Weco. Weco is the North American distribution partner of Ceramicx. The full system was in the final stages of assembly in Modern's factory.

**So how big is big? The Modern Model 9' x 23' SS (Single Station Shuttle) vacuum forming machine has a work area measuring 9 feet by 23 feet (2.7 m by 7 m). Modern's customer will primarily be using**

**the system to form swimming pools for rehabilitation therapy and hot tubs.**

The Ceramicx oven designed and built by Modern Machine using Ceramicx ceramic heating components sourced



from Weco International consists of a top platen (visible in photo) and a bottom platen, each measuring 11 feet by 24 feet (3.4 m by 7.3 m) and each having 754 Ceramicx FTE ceramic infrared heating elements. There are 754 heating zones wired for 2 elements per zone of percentage control through the PLC operating system.

**1,508 FTE ceramic infrared heating elements**  
**754 heating zones**

Well-known as a designer and manufacturer of a broad variety of thermoforming machines and systems, Modern Machine has worked closely with Weco and Ceramicx for some time. Many of its machines have been shipped with Ceramicx heating technology. The thermoformer who will be using this big shuttle machine already had one of Modern's machines. Modern's Vince Hicks says those machines use quartz heating technology, but for this large machine the customer wanted to work with IR ceramic-based technology from Ceramicx and Weco.

Although most people immediately think of packaging when they hear the word thermoforming, the other products that make up about 15 percent of the North American thermoforming business also are growing, and many of those are large: bases for dental chairs, logistics containers, car hoods/bonnets, pickup truck bed liners and many more.

At the recent SPE Thermoforming Conference where Ceramicx and Weco exhibited, large parts were numerous, and more than a few of them had been converted to thermoforming from injection molding and reaction injection molding (RIM).

Generally speaking, if a part is large and production volume is low, the economics of thermoforming can beat out injection molding. Competing against RIM, thermoforming can offer lower part weight, lower cost tooling and better surface finish, including high gloss. It is likely that more big things are in store for thermoforming.

**U.S. thermoforming market:**

**Steady to Better**

**Recent data on the American thermoforming market augurs positively for Ceramicx and Weco International, its North American business partner. According to Plastics News' research, North American thermoforming sales reached \$11.4 billion in 2014.**

Plastics News goes on to say that, absent any unforeseen geopolitical factors, the current upward trend for thermoformers is expected to continue.

American Thermoforming sales 2014

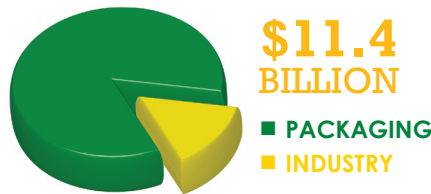

Plastics News identifies packaging design innovations as the fuel for growth and creation of new opportunities for thermoformers. Packaging, it says, accounts for about 85 percent of the thermoforming business, or about \$9.6 billion of the 2014 market total of \$11.4 billion. Looking forward, Plastics News forecasts that packaging's 85 percent of the thermoforming market will be worth \$10.2 billion in 2015 and \$10.8 billion in 2016. That's certainly good news for the thermoformers and for equipment suppliers like Ceramicx and Weco — and it could get even better for them due to increased activity in the non-packaging part of thermoforming.

Ceramicx/Weco business with American thermoformers making plastics packaging is going from strength to strength, but awareness of and interest in high performance infrared process heating is rising among all thermoformers. Ceramicx and Weco are finding new applications among the 15 percent of thermoformers not making packaging. That sector is usually called "industrial" but "other-than-packaging" would be a better description as it includes a broad diversity of products. Weco, as the article on page 4 makes clear, is currently working with many new opportunities for Ceramicx technology outside packaging, for example in the currently surging North American automotive industry, in the aerospace market and in a steadily growing composites sector.

The "steady to better" estimate of the U.S. thermoforming market in our headline comes from Bill Wood of Mountaintop Economics & Research,

an economic analyst specializing in the plastics industry. Wood also is Economics Editor of Plastics News and writes its Business Monitor column. In his August 26, 2015 column, he wrote, "Thermoformers are becoming less pessimistic about their business prospects, and that appears to spell good news for the sector for the rest of 2015. His Plastics News Business Monitor thermoforming index for the second quarter of 2015 was 113.6, up from 101.9 in the first quarter. A number above 100 indicates overall business activity increased from the previous quarter. Thermoforming is trending up.

Wood and his crew survey a large sample of North American thermoformers quarterly regarding new orders, production levels, number of employees, and other data points. He says that for the vast majority of the thermoformers surveyed in the second quarter, business conditions are best described as steady-to-better. The survey also asks about expectations for future business and the sub-index for future expectations in the second quarter was a very optimistic 154.7. It was 133.3 in the first quarter survey so this is definitely better. To reach 154.7, well over half the respondents said they expected conditions to improve, while only 3 percent expect them to get worse.

Another future-looking question in Wood's survey asks thermoformers about their capital spending plans. Wood calls the sub-index for that question in the second quarter a "solid 125.8". The number of respondents expecting to spend less dropped, while the number expecting no change jumped. Wood says a decision to purchase capital equipment, for example a new infrared process heating system, involves a great deal of analysis and forecasting, and a great deal of optimism. Very few business people will seriously consider investing in new equipment, he says, if they are not optimistic about the future. He expects the trend in future expectations, which is positive, to correlate with capital spending plans most of the time.

Wood says his "unscientific and informal conversations" with people involved in the thermoforming sector and their suppliers corroborate the overall trend in his survey data through the first half of 2015. They tell him that business levels are improving and they expect them to stay on track in the coming year. "New market opportunities are emerging," he says, "especially in the United States and Mexico."

# Ceramicx and TCD enter Industry 4.0 *with the* CIRCLE

Readers of HeatWorks magazine will know of the long-standing collaboration between Ceramicx and Trinity College Dublin (TCD).

**As Ceramicx sets out on its fourth Innovation Partnership award from Enterprise Ireland we hear from Dr Garret O'Donnell of TCD on how his organisation will be playing its part; helping equip Ceramicx with advanced tools for further market leadership.**

Over the last number of years, researchers within the Mechanical & Manufacturing Engineering (MME) department at Trinity College Dublin have been leveraging state-of-the-art sensing & inspection technologies in applied research in fluid and heat transfer and in manufacturing technology & systems.

Commercial opportunities for this applied research output lie primarily in manufacturing sectors. For this reason MME academics are actively engaged with industry. Since there is strong synergy between the active research themes in the department and the core IR heating business of Ceramicx Ireland - and the two of us have an established collaborative relationship spanning several years - TCD is the natural choice of partner for Ceramicx in the development of the new product testing and validation capability.

We know Ceramicx of course as a successful export-driven SME business, designing and making ceramic & quartz infrared (IR) heating elements and complete turnkey infrared heating systems for industrial and commercial applications, with special focus on Packaging, Aerospace and Automotive Industries with other industries such as oil gas and food playing a smaller role.

We also know that Ceramicx has a very strong track record of collaboration with Irish and European based research institutions including university partnerships - with the University of Limerick, the University of Duisburg Essen, Cambridge University, the Cork Institute of Technology, Belfast Metropolitan College and Trinity College Dublin.

The company's 'Centre for Infrared Innovation' (C<sup>2</sup>I<sup>2</sup>) work has been reported in these pages and in this issue. Its state-of-the-art infrared energy mapping instrument, the 'Herschel' is coming into its own (see 1st article in this issue) and was developed in conjunction with our own thermodynamics specialist Prof. Tony Robinson of Trinity College Dublin through an EI supported Innovation Partnership.

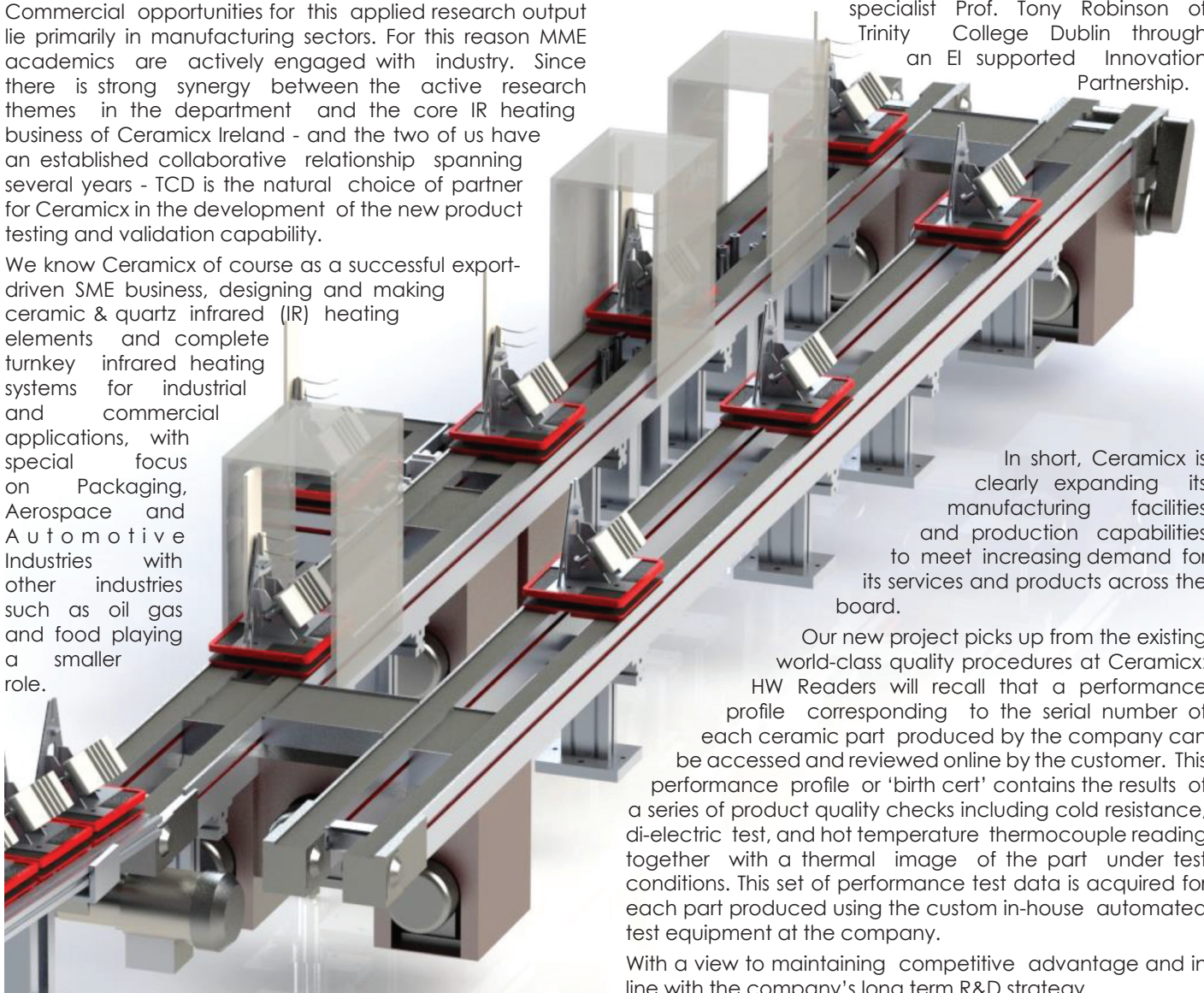

In short, Ceramicx is clearly expanding its manufacturing facilities and production capabilities to meet increasing demand for its services and products across the board.

Our new project picks up from the existing world-class quality procedures at Ceramicx: HW Readers will recall that a performance profile corresponding to the serial number of each ceramic part produced by the company can be accessed and reviewed online by the customer. This performance profile or 'birth cert' contains the results of a series of product quality checks including cold resistance, di-electric test, and hot temperature thermocouple reading together with a thermal image of the part under test conditions. This set of performance test data is acquired for each part produced using the custom in-house automated test equipment at the company.

With a view to maintaining competitive advantage and in line with the company's long term R&D strategy,



Ceramicx has now decided to radically enhance its existing product testing and validation capability, entering the 4th industrial revolution with a smart manufacturing tool which will drive the ceramic and quartz product process.

Our new project will therefore create an infrared characterisation laboratory equipment infrastructure (CIRCLE). It will be used both to validate existing product performance and characterise new product design prototypes.

CIRCLE will provide Ceramicx with a new and enhanced testing infrastructure, one that will enable the company to categorise manufactured parts by conformity tolerances, identify and measure current process variations, and also thereby improve understanding of those factors that influence product quality and performance.

Furthermore, the mechanical, electrical and software design of a system and subcomponents to deliver this functionality will require expertise across a range of specialist disciplines in addition to CI's own niche knowledge and expertise.

Our new project will therefore develop a dual use system for infrared heater characterisation and high speed production conformance testing; one that is tailored to the unique operational needs of Ceramicx. This will combine functionality with a novel flexible test sequencing concept, namely:

- The core testing capabilities of CI's existing CVS final test machine
- A heat flux measurement capability such as that currently provided by the Herschel R&D machine
- A suite of additional part qualitative tests e.g. weight measurement, thermal characteristics
- A database with large data storage capability and associated software tools to allow simple access, smart interrogation and visualisation of desired part parameters, test results for the purposes of data/process trending and analysis
- Smart database software tools to provide multiple parameter selection with cross comparison and presentation to allow CI gain the maximum production and research benefit from stored test data.

These outcomes will greatly aid Ceramicx in identifying the critical performance parameters responsible for focusing IR heatwork and minimising spectral mismatches. The CIRCLE system will also provide Ceramicx with the means to confidently provide high-specification engineered parts for customers and for research purposes.

Further features of the CIRCLE system will include:

- A unique array of sensing & measurement capabilities including multi-point IR
- Intensity measurement of assembled IR heaters (parts)
- Thermal imaging of parts, temperature (TC) measurement of parts, dielectric & resistance measurement of parts, and weight measurement of parts.
- Custom-designed multi-function testing stations, each of which may be configured to implement a variety of tests (in-order to maximise part throughput when the machine is used for in-production testing).
- Custom automated part/test-cradle handling systems to convey one or multiple parts between testing stations based on a flexible user defined test sequence
- Ad-hoc and customised R&D part characterisation tests

- A novel instrumented part test cradle design which will be used to hold parts and terminate part electrical leads for testing purposes.

Each one of the new cradle designs will provide: in-built electrical connectors for connection of ceramic & quartz part Power & TC leads; electrical ports to accommodate automated make/break connectivity so that the cradle can be moved between testing stations in any sequence.

The project will also provide a suite of IR-specific testing and software tools for test visualisation, configuration & control; test data acquisition & processing; test database management; part identity tracking; and test report generation.

Over the coming months the CIRCLE project will equip Ceramicx with a capability that is not readily available to its competitors internationally and will ensure that the company increases its competitive advantage as a key supplier in the niche IR heating sector.

CIRCLE will also deliver a range of tools to support the dynamics of diagnostic development within the company.

The key objectives in this aspect of the work will be to develop

- A robust scalable testing and research platform to accommodate existing and future testing needs
- Methodology to deliver consistent diagnostic data on a range of Ceramicx products
- Advanced test-data logging and storage capabilities that facilitate in-house data mining and analysis for R&D purposes (and will also enable Ceramicx to provide seamless data exchange with customers partners (internal/external)
- Software functionality to support diagnostic engineers and NOT data format expert (diagnostics oriented GUI)
- Ceramicx's capability to develop new products and optimise part & process design through improved visibility of significant input factors that contribute to process variation.
- A platform to facilitate productivity improvement in surrounding processes

All of the innovation that CIRCLE delivers will undoubtedly support the emerging markets for Ceramicx IR heatwork in industry, including developing markets in packaging, automotive aerospace, oil and gas, and many others.

The current trend towards metals substitution in manufacturing, for example, is creating a growth opportunity in the supply of IR heating solutions in polymer-based and carbon fibre manufacturing processes. New IR heating product innovations by Ceramicx are now helping to facilitate moves by the automotive and aerospace industries towards producing mass volume body panels in carbon fibre materials. All of this and more will be helped and facilitated by the CIRCLE. We are very much looking forward to being a part of it.



Ceramicx and Trinity would like to extend their thanks to Enterprise Ireland for their financial support under the Innovation Partnership Programme.



**Dr. Garret O'Donnell**  
 Mechanical & Manufacturing Engineering.  
 Trinity College Dublin, College Green, Dublin2.  
 Garret.O'Donnell@tcd.ie



# Ceramicx joins Euro project for medical part products

Ceramicx is pleased to announce that it has been selected as one of a nine company pan-European team who will develop ceramic-based products for medical treatment under the 2020 EU business development frame work.

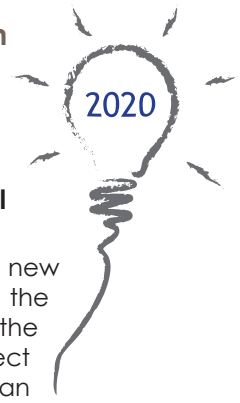

The project is titled 'development of ceramic and multi material components by additive manufacturing methods for personalized medical products' and begins forthwith. A formal launch was held in Brussels at the end of October 2015.

Dr Cáthál Wilson of Ceramicx says that 'our company is delighted to be a part of this ground-breaking new work. Our own research – with Trinity College Dublin - into the effects of IR-based ceramic heat on the human body confirms to us that there are many positive attributes of IR heating. Not for nothing is IR heat the source of choice in many healthcare, sauna and veterinary applications. We hope that this new project will enable deeper understanding of the role of ceramic in medicine further – and catalyse its use in human healthcare.'

The lead body and coordinator for the CerAMufacturing project is the prestigious Fraunhofer Institute (based in Dresden, Germany). In addition to Ceramicx, seven other European companies will take part. They are: ADMATEC; eye-d; HAGE; Montanuniversität Leoben; Inmatec Technologies GmbH; CeramTec GmbH and Eurogrant GmbH.

for personalized medical products – micro surgical tools, implants, and remedies – such as consumer products will be manufactured starting with the patient-specific physical dimensions and will finish up with components that have been validated under practically relevant conditions.



Participants of the cerAMufacturing project at the groups inaugural meeting held in Brussels this October .

The cerAMufacturing project intends to develop a completely new approach for ceramic multi material additive manufacturing which will allow series production of customised and multifunctional components for manifold applications for obtaining property combinations, such as electrical conductive/electrical insulating, dense/porous or two-coloured components.

The project intends to develop five case studies: Demonstrators

In order to achieve these goals manifold tasks will be solved starting with method and device development. Suspension-based additive manufacturing methods will be developed and qualified in cerAMufacturing, because this route promises a much better component performance when compared to powder based methods.

Multi material applications will also play a dominant role in the project. Ceramic/ceramic and also ceramic/metal material combinations will be developed. For that purpose either additive manufacturing methods will be qualified or AM methods will be combined with conventional shaping routes such as tape casting or ceramic injection moulding.

The last mentioned combination of technologies will allow the individualisation of large series production components. Appropriate control methodologies to guarantee a high quality level of the custom made products will be implemented. The cerAMufacturing project will also provide the necessary technical equipment for combining AM steps with conventional ceramic shaping routes.



European Commission

HORIZON 2020

The EU Framework Programme for Research and Innovation





# SPE Thermoformers line up Barcelona for March 2016

HeatWorks magazine is pleased to welcome back Ken Braney, here to tell us about the upcoming and special 20th anniversary meeting of the SPE European Thermoforming Division



Ken Braney

The SPE European Thermoforming Division is proud to announce the **10th Bi-Annual European Thermoforming Conference that is to be held in Sitges (Barcelona) 10-11 March, 2016**. It is a very special occasion as it celebrates the 20th Anniversary of the start of the SPE European Thermoforming Division (ETD).



The SPE ETD Thermoforming Division started with a small gathering of delegates at the original conference held in Germany. This has now grown to become an event that is unique; attracting visitors from all over the world and leaders from the thermoforming industry. The theme of this conference in 2016 is Evolution, Thermoforming, Destination and it will reflect not only what has happened over the past 20 years but also to discuss the future.

If you are a part of the thermoforming industries this, in my opinion, is a conference you should not miss: You will be able to gain information on the latest opportunities and technology, as well as networking with other members of the thermoforming sector.

We are currently lining up leading speakers on many subjects associated with the thermoforming industry. Senior personnel from major manufacturers will speak on what they expect and require from their thermoforming suppliers, extrusion companies talking about the latest improvements in their equipment, tooling companies on how they can improve productivity, heater manufacturers on how to improve productivity and reduce costs. All speakers will bring something new and exciting to the delegates

We have speakers from both Europe and USA reflecting on their thermoforming company's history and where they see the growth coming in the future. This always gives fascinating insights into the process of many major thermoforming companies and their forward looking plans.

3D printing – or additive manufacturing – will be another major topic as it is now becoming an important part of all of manufacturing, thermoforming included. The general impact is growing significantly and a number of companies have now embraced the technology. The conference will explore these and many new ideas.

As always there will be a technical training program in both thin and heavy gauge thermoforming. We will have separate sessions on both and we will be announcing the full program shortly.

Plastic Packaging will be a subject presented from not only the historical view but also the future expectations from material usage to design expectations.

Simulation programs used to replicate the forming process have been around

for a period of time. However there are new and exciting developments in this field and we will have speakers explaining the new innovations at the conference.

The main suppliers - thermoforming machinery, tooling, extrusion, material companies, and heating companies - will not only be presenting but will also have table top displays. This gives all attendees the opportunity to meet and discuss topical matters directly with their suppliers. The 10th SPE ETD Thermoforming Conference will have a large number of table top displays manned by the major suppliers to our industry. These companies will show their latest innovations and product releases.

A parts competition is an integral part of the SPE ETD Thermoforming Conference and all are welcome to submit parts. The last competition produced a variety of specialised items and the winner was then put into a worldwide competition for all plastic products. This competition was held in the USA and the part submitted from the SPE ETD conference was voted the overall winner

The other reason why everybody should always attend the SPE ETD Conference is the great opportunity for networking, allowing the delegate to meet and discuss with people from all around the world who have experience in the industry. I urge all in the industry to attend this important event – and look forward to welcoming you there in March next year.

For all further details please contact Yetty Pauwels at [spe.etc@skynet.be](mailto:spe.etc@skynet.be) for details on sponsoring as well as conference attendance.

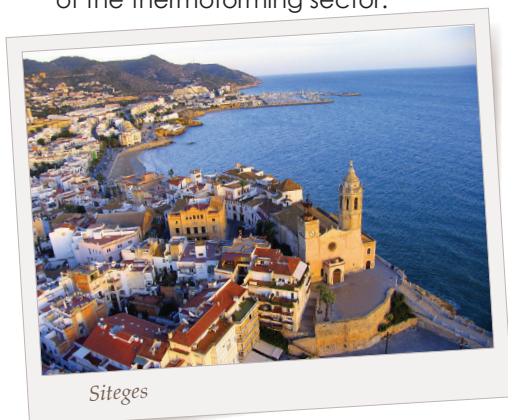

Sitges

# Fusion project takes form

As part of the All Island Knowledge Transfer Initiative in Ireland Ceramicx is teaming up with Belfast Metropolitan College in order to develop methods of curing composite materials.

The proposed Fusion project will run over the next 18 months and will look at the infra-red curing of carbon fibre / epoxy composites and the manufacture of an improved drape forming machine.

Specifically the project will research the necessary factors for facilitating the appropriate curing of epoxy resin in a carbon fibre composite.

This will also include a method of processing the cured composites in order to minimise voids and other matters in order to reach the standards necessary to produce aerospace grade primary structures.

Following the research and development phase, the project will focus on co-ordinating the design & development of a prototype production drape forming machine. This will then form the basis of machine sales to international customers

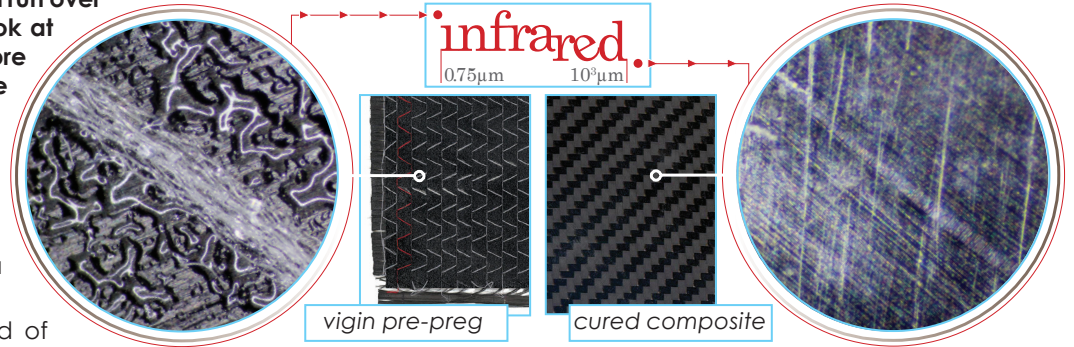

provide a counter-balance for the practical go forward operational nature of Ceramicx. This piece of equipment will take on-board all the extensive learning and research by Belfast Met, and the college's experience in dealing with drape forming issues in order to ensure that the piece of equipment is as comprehensive a market solution as possible.

The global composites machinery market is in its relative infancy. The building of equipment, machinery and ovens for this market does not yet appear to have developed global players; possibly as a result of the fact that there as yet has been no real engagement in the research and development of the required heatwork.

Heatwork indeed is the primary factor of concern if the bottlenecks that these pieces of equipment represent are to be overcome. Cáthál notes that 'the machines in this area are entirely based on heat processing but the market does not appear to yet have any expertise on heatwork processing!'

The proposed new machine development (i.e. the primary deliverable of this project) will therefore be carried out in conjunction with Belfast Met so as to ensure that all the variables surrounding the resin, composite material and its heatwork and processing are considered and maximised to produce a piece of machinery that will surpass anything currently on the market and will also move production towards out-of-autoclave production.

Machines of this nature are typically called 'Drape Formers', 'Hot Drape Formers', or 'Pre-Formers', all of which refer to the same thing. Drape forming machines come in various sizes depending on their targeted product. The smallest machine that Ceramicx has come across retails from for £150,000 while there are larger machines that have been sold for aerospace wing production for as much as £2million.

...a key area of focus is on **OOA** solutions.

Current methods of composites production are labour intensive and slow. Capital equipment can also be expensive and create a bottleneck in production (e.g. autoclave). Therefore a key area of focus is on OOA (Out of Autoclave) solutions.

A major solution appears to be the Drape Forming machine which has advanced features in relation to fast cycle times, high quality finish with sound product integrity, and ease of operation. A key prerequisite for improved Drape Formers is improved knowledge on resin behaviour, advantages of infrared curing and any additional enhancement factors such as vibration, vacuum etc.

Dr Cáthál Wilson is leading the Ceramicx side of the project and notes that 'the level of research into highly specialized composite resins is not something which we specialize in at present. Ceramicx would therefore benefit from the ability to cure composite components with Belfast Metropolitan's knowledge and experience of resin curing in composite processing. In addition Belfast Metropolitan College can perform characterizations with regard to resin rheology, and any additional enhancement factors such as vibration and vacuum levels.'

Another key factor is the familiarity and profile which Belfast Met already has with key players in the composites industry; resin suppliers and end-users for example. Ceramicx in conjunction with Belfast Met would be better able to tap into these new markets.

Belfast Met's research approach to composites will also





# Wake Up TO COST REDUCTION

Consultant David Russell pulled no punches when presenting on thermoforming energy savings to the Plastics Design and Moulding (PDM) exhibition in Telford this summer. HeatWorks magazine caught up with him for this edition.



David Russel

The cover of Heatworks 3 stated 'We have AAA rated fridges, fuel efficient cars, but energy-hungry machines ... are not even considered.'

In my experience the knowledge of energy efficiency in energy-hungry thermoforming machines is not as good as it could and should be. The industry needs to learn to properly address the issue of energy efficiency, quality and cost reduction – the No1 Key Driver for Innovation in 2015 according to the July 2015 survey by Packaging News magazine.

On heater troubleshooting assignments I always start with a checklist of questions which normally flush out the problem areas

**We have AAA rated fridges, fuel efficient cars, but energy-hungry machines ... are not even considered**

## Q1 Are you getting hot/cold spots?

When the answer is yes – and it usually is - we find the platens have a range of old and new elements – and occasionally elements of the wrong wattage. On two shift working most types of heating element will have lost about 40% of their efficiency within just two years. A planned maintenance replacement of ovens every two years is therefore a cheap and effective way of maximising the use of input energy – and maintaining short cycle times and control over the sheet.

## Q2 Is all the input energy reflected towards the sheet?

Infrared elements emit heat over 360° – so a huge amount of input energy could be wasted and go to heating the frame of the machine and the atmosphere rather than the sheet. Most modern machines use some sort of reflectors – but not all reflector types and materials are effective. Aluminised Steel, as developed by Ceramicx, has been found to be the best (and hollow ceramic-based elements with internal insulation are often more effective than solid elements).

## Q3 Are your heaters matched to the application/material type?

Thermoforming is typically found to be the least energy efficient plastics process, typically accounting for 60% of a factory's energy bill – 6.2kWh/kg/hr compared to a figure of 3.1 for Injection Moulding (Source Northern Ireland Polymer Association (NIPA)). So using elements emitting the optimum wavelength of energy for the polymer being formed is crucial.

In response to this need, Ceramicx have established a research and development department – "Ceramicx Centre for Infrared Innovation" – shortened to C<sup>2</sup>I.

The main functions of the Centre are to:

- Conduct IR heat mapping and testing of all types of heaters – on the 'Herschel' – an energy mapping instrument,
- Assist in IR heater product design and development,
  - Offer IR heat mapping and testing on all forms of target bodies, materials and applications,
  - Publish this research, where possible, with partner research institutions.

*(Please see pages 1-4 of this issue for a demonstration of this work in action)*

## Q4 Do your engineers fully understand IR heating?

The (truthful) answer is invariably No. To increase the level of technical knowledge in IR heating Ceramicx has prepared a free internet based Industrial Infrared Training Course for their customers.

This course is the most comprehensive primer on the use of Infrared in Industrial Heating. Its audience is engineers and professionals in Industrial Heat processing.

## Q5 Are you thinking about improving efficiency by buying a new machine?

To which my response is often 'guess again' The core of every thermoforming machine is the oven – so replacing an old oven with a state-of-the-art Infrared oven is an effective and quick way of restoring performance, reducing cost and saving capital spend.

Ceramicx-designed systems essentially convert incoming wattage (11111) efficiently into heating the plastic – resulting in reduced cycle times, improved control over the sheet – and cost reduction.

A recent Ceramicx-designed retrofit at a UK moulder resulted in a 41.5% reduction in power drawn. The moulder has now embarked on a planned oven retrofit programme across their whole business.

Another Ceramicx retrofit in the USA increased Shots/Min from 15.2 to 23.4 – with a new oven reduced in size from 160" to 80".

### In summary:-

Ceramicx are undoubtedly the market leaders in the development of Infrared heaters. Thermoforming businesses and engineers can use Ceramicx expertise to:-

- Reduce energy cost – through oven renewal/retrofits – with reflectors,
- Restore control over the sheet – improve quality,
- 'Tune' and match IR heat sources to various kinds of polymers by using the C<sup>2</sup>I centre and the 'Herschel' test instrument.
- Access the online Infrared Training Course – free to customers.



# The Freek and Ceramicx show again

Autumn saw an intensive programme of joint activity between Ceramicx and its German distributor partner, Friedr Freek.

The two companies showed products on the same booth at the Fakuma plastics exhibition in Southern Germany.

Injection moulding purists may be not a little put out that, for the first time, the Fakuma exhibition featured a new thermoforming-based centre, situated in Foyer West.

To be sure this is not a huge space but it happened to be situated right next to the Freek booth. Freek director Stefan Kaiser noted that 'to use this as an opportunity we registered Ceramicx this time as our co-exhibitor. By doing so we attracted as many IR heat interested visitors to our stand as possible.'

The Fakuma show – annual each year except in a K show year – still retains its character as primarily injection moulding based and for German speaking customers and suppliers.

At this year's event Ceramicx partner Freek put particular focus on its miniaturization successes. With this kind of focus the German company gives further support to the leading hot runner manufacturers in producing even more compact, precise and thus resource and energy efficient nozzles and hot runners.



Freek hot runner heaters – smaller, faster, hotter!

After another 'all-time-high' through the past business year and a continuous expansion path Freek feels vindicated in its innovation and cooperation strategy.

An important key to this success is the company KSG Gerätetechnik in Waldheim, Saxony, co-founded by Freek in 1991. It originally used to manufacture simple standard heating elements but in the meantime the number of nozzle heaters manufactured for Freek has steadily increased. The parallel manufacturing in Waldheim has been designed for a large series of products. This factor guarantees Freek nozzle

heaters to be even more competitive without endangering the high flexibility and innovation dynamics at Menden.

Freek is also very pleased that not only its own sites in Menden and Waldheim but also the associated EUCOPET partners in Italy, England and Ireland continue to benefit from a 20-year-long programme of cooperation.

The mainly small and medium-sized (SME) network of Freek partners employs a total of more than 300 staff members - and manufactures the complete range of electric industrial

heating elements. Freek will show the latest novelty of this network cooperation - the ex-protected drum and bulk container heaters –as well as the new infrared emitter generation from Ceramicx.

Ceramicx displayed all its latest componentry and innovation in thermoforming production as well as some of its more recent IR heat source oven designs. Director C ath al Wilson says that 'Ceramicx is delighted to be once again taking part in Fakuma. As thermoforming approaches new heights in precision plastics processing it is only natural that the thermoforming process plays a significant part in the show proceedings. Long may such a feature continue!' ■



The stand at Fakuma led to some lively discussions



The special challenge here is the adherence to the high electric test standards self-imposed by Freek. Even the tiny 1,0 x 1,6 mm Mini-MicroCoils resist 1000V high voltage due to the research work carried out, and involving suppliers, partner companies and research institutes. With almost 1GOhm insulation resistance these products are above the required norm specifications by several powers of ten.

Also the cross section and diameter tolerances of Freek nozzle heaters are lower than the market standard of +/-0,15 mm by some two thirds – this applies to even the smallest heaters.

Especially for heating elements pressed into a groove this tight tolerance has positive effects regarding a reliable good and thus efficient heat transfer.





COMPOSITES EUROPE

# Putting the heat on composites

Composites are one of the key technologies in light construction and Germany's Composite Europe exhibition continues to reflect the growing market for light materials.

Composites are one of the key technologies in light construction and Germany's Composite Europe

Composites are one of the key technologies in light construction and Germany's Composite Europe exhibition continues to reflect the growing market for light materials.

From 22–24 September, the trade fair in Stuttgart exhibited a whole range of fibre-reinforced plastics, among which were numerous innovations in the applications of automobile construction, air and space travel, boat construction, wind energy and the construction sector.

Ceramicx director Dr Cáthál Wilson toured the event with Stefan Kaiser and Stefan Düelmann of Ceramicx German distributor, Friedr Freek.

Cáthál said that 'day-to-day our work at Ceramicx takes us further into the heartland of composites production. These materials and these constructions are an inescapable part of our modern manufacturing future. It is therefore entirely right that Ceramicx IR heat technology continue to be a part of the growing composites sector.'

Freek director Stefan Kaiser commented that 'although the show size with about 400 exhibitors was less than a quarter of our forthcoming Fakuma exhibition, every hour we have spent here has paid off.

Firstly, and with help from Cáthál, we have definitely benefited from a deeper insight into this still very young industry and its process chains. Secondly we are interested to see that the composites market has a huge growth potential and holds a lot of exciting opportunities for IR heat work.'

On its 10th anniversary, the trade fair has set new records. The coming-together of 450 exhibitors from 30 nations emphasises the international significance of the show, which has continuously performed at record levels since its inauguration. For the first time, this year the event is held across three fair halls.

The exhibition is also promoting new themes, programme highlights and

premieres. In addition to automation for serial production and new light construction concepts, future themes, such as material repairs of fibre-reinforced plastic components, potential biologically based materials and of basalt fibres, are increasingly adopted.

In total, 11,000 light construction experts, from automobile construction, aerospace, mechanical construction, boat construction, wind energy and the construction sector are expected to have attended the Mess Stuttgart exhibition grounds, and one third of these from overseas.

The greatest challenge for the industry remains the development and optimisation of mass-production manufacturing and the processing of composite components. Several show innovations were unveiled in this regard, showing the appropriate production and processing procedures, material innovations and current light construction projects.

In the Product Demonstration Area, one of the visitor highlights of each was where the fair assembles new high-tech products and makes "experience-able" the existence of composites components in live demonstrations. Among the exhibitors were Evonik Industries, the Institute for Aeroplane Construction from the University of Stuttgart, Euro-RTM-Group, RH Schneidtechnik and Piekenbrink Composites.

In the specialist area, "Industry meets Science".

Whether used as dashboard, in car door panels or as service cars in aeroplanes, wood and natural fibres such as cotton, flax fibres, hemp, jute and kenaf are increasingly gaining significance as biological composites. Together with the Nova Institute, Composites Europe set out to show how good sustainability can exist in light construction. More than 20 businesses exhibited their products at the fair in this way, ranging from plastic



Time out to visit the Zollverein Coal Mine Industrial Complex in Rhur Valley, a Unesco World Heritage Site since 2001

materials made from meadow grass through to flax fleece and reinforced volcanic rock filaments.

In addition, the 1st International Composites Congress (ICC took place 21–22 September 2015 in Stuttgart. The congress replaced the previous AVK conference and in the future will be organised by the Trade Association of Composites Germany as a prelude to the fair. The conference documented the innovations in the area of fibre-reinforced plastics. The international podium discussion at the end of the congress addressed the question, "Composites – a key technology for high-income countries from the viewpoint of machinery manufacturers?"

Multi-material networks have long established themselves in automobile construction, electronics or medical technology. The Hybrid Expo, which takes place in parallel to Composites Europe, showed innovative hybrid construction solutions.

The 70+ international exhibitors include many branches from machine construction, tool construction, and research and development, as well as numerous suppliers of complete solutions, showing the entire process chain around the serial manufacture of hybrid components. Of particular focus this year was process integration and acceleration in the manufacture of metal-plastic compounds.



# Discovering the Potential

## Ceramicx Turkey continues to gather pace.

It's world-beating IR heat technology is winning orders from that country's thermoformers and machine builders alike. Manager Hasan Duman gives us the highlights from the past six months.

Turkey has been a hub of ideas and cultures for over 10,000 years. It has been home to Mesopotamia, the Ottoman empire, parts of the Silk Road and some even say that the wheel was invented here

Our land and its people have been the home of innovation for time out of mind. More recently the reforms of Kemal Atatürk brought our country forward into the 21st century and have opened our doors to renewed trade.

### Rapidly growing sales

After Ceramicx Turkey's third month of business our sales numbers have been showing exponential growth.

Our marketing efforts have paid off instantly; merging good prices and world-class quality. Our number one quality policy – as evidenced by the Ceramicx product 'birth certificate' has been very effective in securing customer confidence in the product.

At this point in time we have also unearthed some hidden markets within Turkey in order to expand our sales. Numerous Turkish industries use some kind of IR heat technology and Ceramicx Turkey is now ideally placed to target those markets; improving efficiency, reliability and value for money with a superior product. We believe that our service, sales and technology will leave the Turkish customer more than satisfied.

### We are problem solvers

Instead of merely selling heaters we set out to be the problem solvers in the industry. With each customer visit the markets further understand our advantages; how can we improve efficiency and processes by using our infrared heating experience and expertise.

When Ceramicx Turkey visits a company we firstly talk about processes and try to understand the customer's key points. From that point on our work begins.

A recent example involves an aluminium foil laminating process. This process was suffering because of the customer mistakenly applying excessive heating – a common enough mistake in IR heat circles.

Simply boosting the temperature – in this case – had done nothing to help matters. Quite the opposite. In this case the over-heating resulted in cables and terminals getting burnt and even the element starting to melt. Following our investigation we supplied short wave IR heating elements – much better suited to this process and one satisfied customer, happy to leave his old heating system behind.

We have also lately encountered a lot of misunderstanding about reflector use in infrared heating. Poor system design

TURKEY

Discover  
the potential



left to right Hacı Taşgıt, Hasan Duman, Muhammad Ali.

and misapplication of IR heat can lead to problems in this area, with every other part of the system getting over-specified. You need better cables to resist heating and lots of space in order to avoid terminal burning. In some cases customers had been fabricating their own insulators to solve problems that had been created with the wrong usage of reflectors. The Ceramicx Turkey expertise can solve this kind of problem at a stroke – upgrading your process or machine to a much better state.

### Hasan's Contact Details

Ceramicx İnfrared Teknolojileri Sanayi ve Tic. Ltd. Şti.  
İkitelli OSB Giyim Sanatkarları İş ve Tic. Mrkz. 3. Ada A Blok No:102,  
Başakşehir / İstanbul  
Tel: +90 212 549 4839 Mobile:+90 544 237 2649  
Email: satis@ceramicx.com www.ceramicx.com.tr



The Ceramicx Turkey Office is now easily recognized as offering this problem-solving expertise. Of course we are also expanding our product range and storage space to have yet even more tools to help our customers.

### Turkish Packaging Machinery advances

Ceramicx Turkey attended iPACK in Istanbul on Sept 14, 2015. We met many friends and customers at this show and Ceramicx Turkey will continue to meet further such; helping them to manufacture and develop more efficient machinery.

iPACK is Turkey's largest packaging event, featuring a wide range of food processing, storing and packaging supplies and equipment from around the world. The exhibition brings together local and international producers and provides them with a platform to share their products and to develop and increase their business.

Chocolate manufacturing was among the more interesting uses of IR heat at the show. Before the filling of the moulds these need to be heated into the proper shape. Long-wave ceramic infrared heaters were being using in an oven to do this job. Most importantly, the ceramic heaters needed to be of very good quality to keep the chocolates safe from ceramic crumbs and dust. At this point we were able to bring the Ceramicx product quality to bear on the conversation and are hopeful of follow up business.

iPack showed significant growth in packaged and processed food, such as ready-to-eat meals and frozen food. Turkey offers excellent investment potential in these areas due to its large population, lack of market maturity, favourable long-term economic structure and GDP per capita. Ceramicx Turkey intends to service all of this growing market for some time to come.

**Plast Eurasia**  
Istanbul 2015

**Plast Eurasia 2015**

The 25th International Istanbul  
Plastics Industry Fair.

**3 - 6 December 2015.**

Tüyap Fair Convention and Congress  
Center, Büyükçekmece, Istanbul/ Türkiye.

# Masters and Doctors at work

**we'll be reporting in more detail on the work of Peter Marshall and Angel Michealraj over the coming months. Here for now, however, is a snap shot profile of the new recruits.**

Aeronautics, materials science, nano technology, physics, polymers, fatigue analysis, heat transfer and many other disciplines are all part and parcel of the two newly arrived skill-sets at Ceramicx.

Peter Marshall says that 'joining Ceramicx has allowed me to combine all my academics - physics, chemistry, polymers and heat transfer - into one role. It's a huge challenge, but it's really exciting and I'm really looking forward to it.

He adds that 'the learning curve has been pretty steep, it wouldn't be fun if it wasn't! Radiation is not a topic that's covered in much depth in university, in fact in most situations, it's virtually ignored completely. Most of my time has been spent getting to grips with composite resins, the current 'state of the art' technology, the chemistry involved and understanding how IR will interact with all of this.

Angel agrees about the state of heating education today. 'Heat transfer is the thing that comes to my mind when I think about the world of heating,' he says. 'The medium and the efficiency is what really matters in heat transfer. Heat transfer through radiation is barely taught in academic circles and finds a limited application as of now. The real advantages of IR such as no medium requirement, and effective and efficient heat transfer signifies and attracts the researchers and industries to study/implement and reap the benefits out of it.'



Peter Marshall and Angel Michealraj

Angel adds that 'IR heating in industry is relatively underutilised which gives us a massive opportunity. When applied properly, not only is IR a quick and very efficient method of heating, it can also be used to target specific layers in a sandwich structure in a way that very few technologies can. The real challenge is to process the heat in an energy efficient way - fit for purpose without adding extra quality costs.

One thing is clear. In terms of IR heat, Ceramicx is now intent on exploiting the properties of materials - particularly the optical ones - in order to ensure efficiency gains are realised. 'Materials have spectral areas where they absorb strongly, weakly and not at all,' says Angel. 'The exciting part of any project with Ceramicx is to use and develop the company's heat technology on various materials to greatest effect - more bangs per buck for all its clients and customers.'

Peter agrees that the work ahead presents equal parts of challenge and creativity. 'Ceramicx is a really dynamic company. There's heaps of great ideas flying around and a lot of progressive and very clever people wanting to make them a reality. One aspect of life I'm most looking forward to is working within, learning from and, contributing to the various teams which Frank and Cáthál have assembled.'

Angel says that 'I believe in the concept of learn, thrive and contribute. Therefore Ceramicx provides a perfect platform - to learn from experts and get to inspired by mentors.'

## CERAMIC ELEMENTS

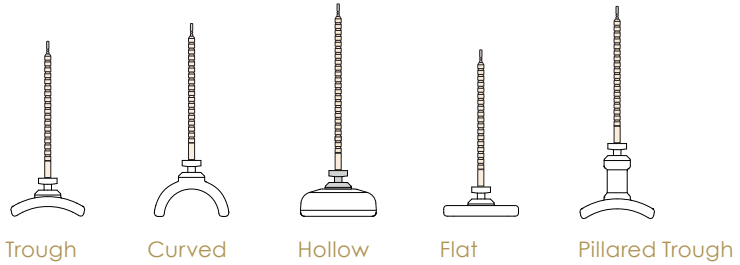

Trough

Curved

Hollow

Flat

Pillared Trough

### CERAMIC TROUGH ELEMENTS

[www.ceramicx.com/trough-elements/](http://www.ceramicx.com/trough-elements/)

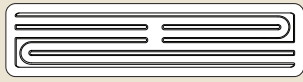

FTE / FTE-LN

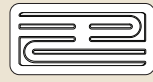

HTE



QTE / QCE

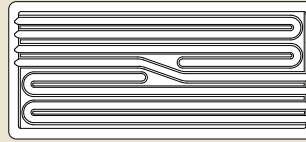

LFTE

FTEL - LN

<b>FTE</b> Full Trough Element	245 x 60 mm	150W 250W 300W 400W 500W 650W 750W 1000W
<b>HTE</b> Half Trough Element	122 x 60 mm	125W 150W 200W 250W 325W 400W 500W
<b>QTE</b> Quarter Trough Element	60 x 60 mm	125W 250W
<b>QCE</b> Quarter Curved Element	60 x 60 mm	150W 250W
<b>LFTE</b> Large Full Trough Element	245 x 110 mm	1000W 1500W
<b>FTE-LN</b> Full Trough Element -Long Neck	245 x 60 mm	250W 400W 500W 650W
<b>FTEL-LN</b> Full Trough Element Long - Long Neck	285 x 60 mm	1000W

### CERAMIC HOLLOW ELEMENTS

[www.ceramicx.com/hollow-elements/](http://www.ceramicx.com/hollow-elements/)



FFEH



HFEH



QFEH

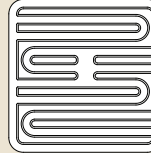

SFEH

<b>FFEH</b> Full Flat Element Hollow	245 x 60 mm	250W 400W 500W 600W 800W
<b>HFEH</b> Half Flat Element Hollow	122 x 60 mm	125W 200W 250W 300W 400W
<b>QFEH</b> Quarter Flat Element Hollow	60 x 60 mm	125W 200W
<b>SFEH</b> Square Flat Element Hollow	122 x 122 mm	250W 400W 500W 600W 800W

### CERAMIC FLAT ELEMENTS

[www.ceramicx.com/flat-elements/](http://www.ceramicx.com/flat-elements/)



FFE



HFE



QFE

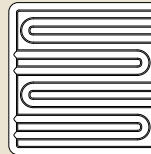

SFSE



LFFE

<b>FFE</b> Full Flat Element	245 x 60 mm	150W 250W 300W 400W 500W 650W 750W 1000W
<b>HFE</b> Half Flat Element	122 x 60 mm	125W 150W 200W 250W 325W 500W
<b>QFE</b> Quarter Flat Element	60 x 60 mm	125W 250W
<b>SFSE</b> Square Flat Solid Element	122 x 122 mm	150W 250W 300W 400W 500W 650W 750W
<b>LFFE</b> Large Full Flat Element	245 x 95 mm	150W 750W 1400W

### THERMOCOUPLES

[www.ceramicx.com/thermocouples/](http://www.ceramicx.com/thermocouples/)



**Thermocouple Type K**  
+ Nickel Chromium  
- Nickel Aluminium



**Thermocouple Type J**  
+ Iron  
- Copper Nickel



## EDISON SCREW ELEMENTS

[www.ceramicx.com/ceramic-bulbs/](http://www.ceramicx.com/ceramic-bulbs/)



ESEB



ESES



ESER

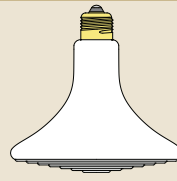

ESEXL

- ESEB** Edison Screw Element Ball
- ESES** Edison Screw Element Small
- ESER** Edison Screw Element Regular
- ESEXL** Edison Screw Element Extra Large

Ø65 x 140 mm	60W 100W
Ø80 x 110 mm	100W
Ø95 x 140 mm	150W 250W
Ø140 x 137 mm	400W

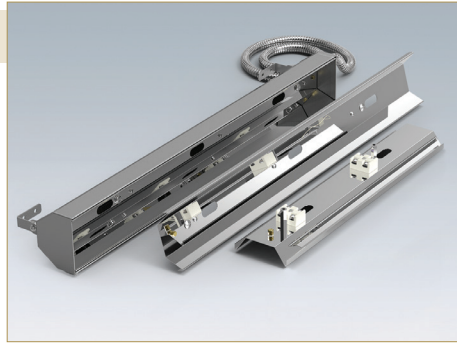

## REFLECTORS / PROJECTORS

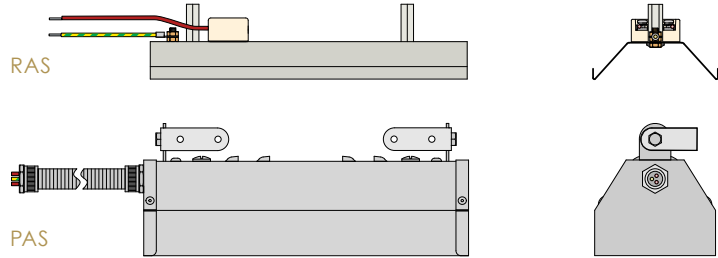

### REFLECTORS

[www.ceramicx.com/reflectors/](http://www.ceramicx.com/reflectors/)

<b>RAS 5</b>	Reflector Aluminised Steel 5	1,254 x 100 mm
<b>RAS 4</b>	Reflector Aluminised Steel 4	1,004 x 100 mm
<b>RAS 3</b>	Reflector Aluminised Steel 3	754 x 100 mm
<b>RAS 2</b>	Reflector Aluminised Steel 2	504 x 100 mm
<b>RAS 1</b>	Reflector Aluminised Steel 1	254 x 100 mm
<b>RAS 0.5</b>	Reflector Aluminised Steel 0.5	160 x 100 mm

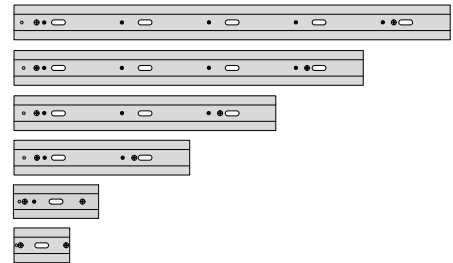

### PROJECTORS

[www.ceramicx.com/projectors/](http://www.ceramicx.com/projectors/)

<b>PAS 5</b>	Projector Aluminised Steel 5	1,258 x 94 mm
<b>PAS 4</b>	Projector Aluminised Steel 4	1,008 x 94 mm
<b>PAS 3</b>	Projector Aluminised Steel 3	758 x 94 mm
<b>PAS 2</b>	Projector Aluminised Steel 2	508 x 94 mm
<b>PAS 1</b>	Projector Aluminised Steel 1	258 x 94 mm

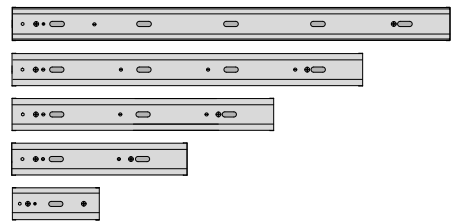

## INSTALLATION OF PILLARED ELEMENTS

[www.ceramicx.com/ceramic-bulbs/](http://www.ceramicx.com/ceramic-bulbs/)

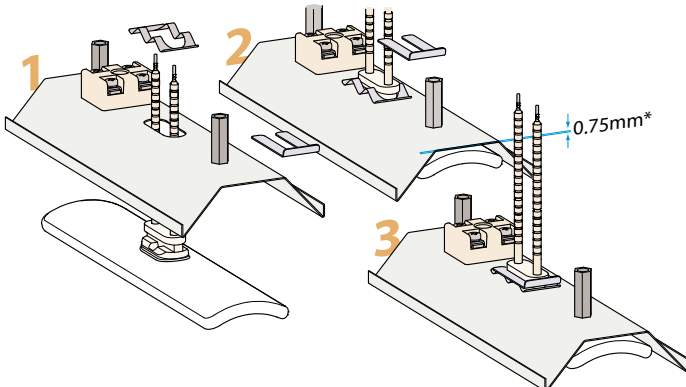

Recommended Slot hole  
size 42 x 15 mm  
1.6535" x 0.5905"

▼ Recommended  
reflector thickness  
0.75 - 0.9 mm  
0.0296" x 0.0354"  
min/max thickness 0.5 - 1.5 mm

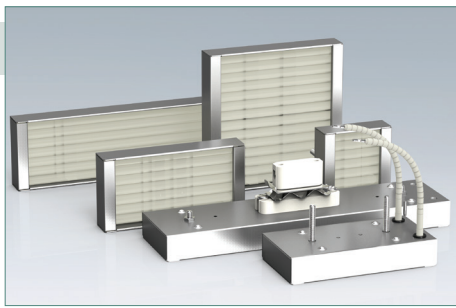

## QUARTZ ELEMENTS

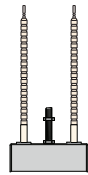

Standard

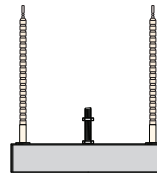

Square



Pillar

### STANDARD QUARTZ ELEMENTS

[www.ceramicx.com/standard-quartz-element/](http://www.ceramicx.com/standard-quartz-element/)

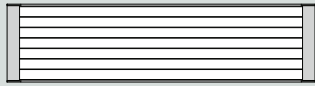

FQE

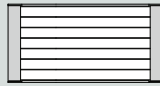

HQE



QQE



SQE

<b>FQE</b> Full Quartz Elements	247 x 62.5 mm	150W 250W 400W 500W 650W 750W 1,000W
<b>HQE</b> Half Quartz Element	124 x 62.5 mm	150W 250W 400W 500W
<b>QQE</b> Quarter Quartz Elements	62.5 x 62.5 mm	150W 250W
<b>SQE</b> Square Quartz Element	124 x 124 mm	150W 650W 1,000W

### PILLARED QUARTZ ELEMENTS

[www.ceramicx.com/pillared-quartz-elements/](http://www.ceramicx.com/pillared-quartz-elements/)

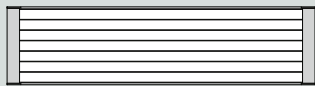

PFQE

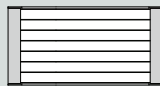

PHQE

<b>PFQE</b> Pillared Full Quartz Elements	247 x 62.5 mm	150W 250W 400W 500W 650W 750W 1,000W
<b>PHQE</b> Pillared Half Quartz Element	124 x 62.5 mm	150W 250W 400W 500W

### CURVED QUARTZ HALF ELEMENTS

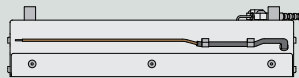

CQHE

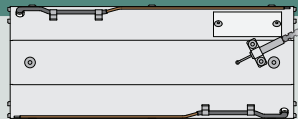
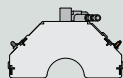

<b>CQHE 500</b> Curved Quartz Half Element 500mm	500 x 100 x 62 mm (inc stand off's)	Wattage 1,250W
<b>CQHE 250</b> Curved Quartz Half Element 250mm	250 x 100 x 62 mm (inc stand off's)	Wattage 625W
<b>CQHE 100</b> Curved Quartz Half Element 100mm	100 x 100 x 62 mm (inc stand off's)	Wattage 250W

### SQUARE QUARTZ TUBE ELEMENTS

[www.ceramicx.com/quartz-square-tube-elements/](http://www.ceramicx.com/quartz-square-tube-elements/)

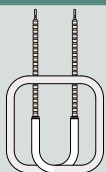

STQH 100

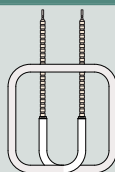

STQH 112

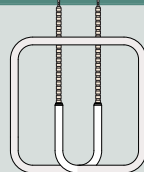

STQH 140

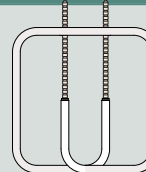

STQH 150

<b>STQH100</b> Square Tube Quartz Heater	100 x 100 mm	150W - 400W
<b>STQH112</b> Square Tube Quartz Heater	112 x 112 mm	150W - 400W
<b>STQH140</b> Square Tube Quartz Heater	140 x 140 mm	150W - 650W
<b>STQH150</b> Square Tube Quartz Heater	150 x 150 mm	150W - 650W



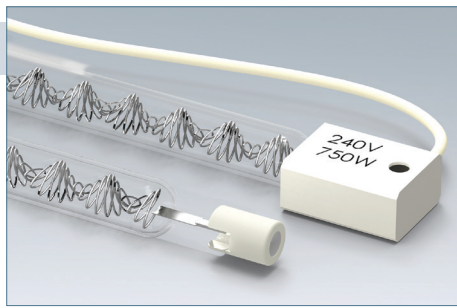

## QUARTZ TUNGSTEN / HALOGEN

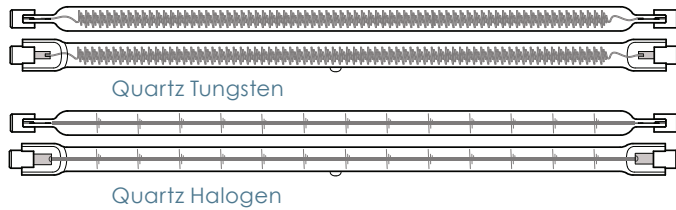

### QUARTZ TUNGSTEN TUBES

[www.ceramicx.com/fast-medium-wave-emitters/](http://www.ceramicx.com/fast-medium-wave-emitters/)

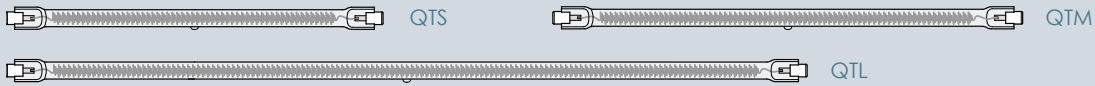

<b>QTS</b> Quartz Tungsten Short	Ø10 x 244 mm	750W
<b>QTM</b> Quartz Tungsten Medium	Ø10 x 277 mm	1000W
<b>QTL</b> Quartz Tungsten Long	Ø10 x 473 mm	1500W 1750W 2000W

### QUARTZ HALOGEN TUBES

[www.ceramicx.com/short-wave-emitters/](http://www.ceramicx.com/short-wave-emitters/)

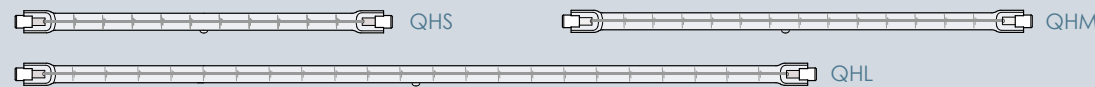

<b>QHS</b> Quartz Halogen Short	Ø10 x 244 mm	750W
<b>QHM</b> Quartz Halogen Medium	Ø10 x 277 mm	1000W
<b>QHL</b> Quartz Halogen Long	Ø10 x 473 mm	1500W 1750W 2000W

### QUARTZ TUNGSTEN/HALOGEN REFLECTORS

[www.ceramicx.com/reflectors/](http://www.ceramicx.com/reflectors/)

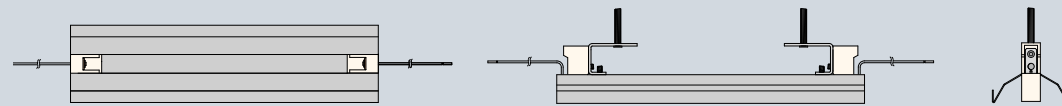

<b>QTSR</b> Quartz Tungsten/Halogen Short Reflector	250 x 62 mm	( Suitable for QTS/QHS, Tubes supplied separately )
<b>QTMR</b> Quartz Tungsten/Halogen Medium Reflector	300 x 62 mm	( Suitable for QTM/QHM, Tubes supplied separately )
<b>QTLR</b> Quartz Tungsten/Halogen Long Reflector	497 x 62 mm	( Suitable for QTL/QHL, Tubes supplied separately )

### SPECIAL TUBE ORDERS

[www.ceramicx.com/special-tube-orders/](http://www.ceramicx.com/special-tube-orders/)

Ceramicx can supply other types of Halogen/ Tungsten elements, of varying design, dimensions, length, coatings, terminations and electrical rating.

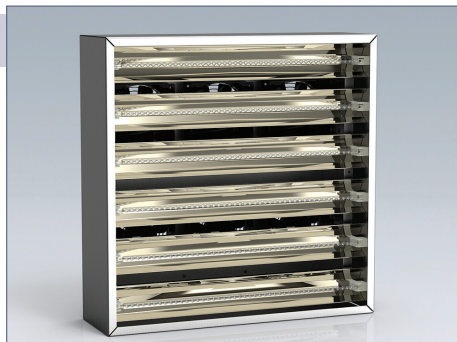

## FAST IR

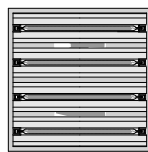

FastIR 305

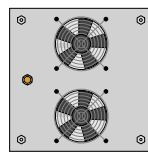

FastIR 500

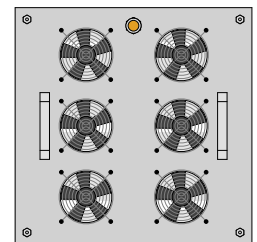
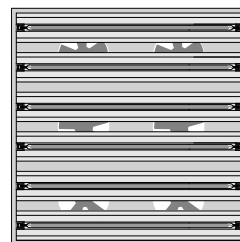

### FAST IR

[www.ceramicx.com/fastir-systems/](http://www.ceramicx.com/fastir-systems/)

<b>FastIR 305</b> Suitable for 1000W Quartz Tungsten/Halogen Heaters QTM/QTH ( tubes sold separately )	305 x 305 x 150 mm	<b>4 Tube</b> 4kW	<b>5 Tube</b> 5kW
--	--------------------	-------------------	-------------------

## CUSTOM PANEL HEATERS

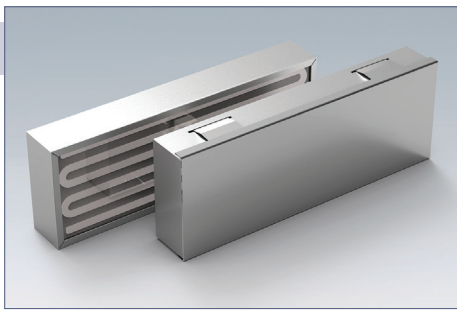

Custom Panel Heaters.  
Available with anodised aluminium or ceramic glass face.  
Range of Wattages and Voltages.  
Multi-zone options with removable miniature thermocouple plug.

## TEST OVENS



1.5kW bench top material test unit.



8kW bench top test unit supplied with 3 interchangeable infrared heating plattens consisting of Ceramic, Quartz and Quartz Tunsten/Halogen Tubes.

The three pieces of lab test equipment shown are tools for determining the best emitter for a given material or job. All are available from Ceramicx, where the first two should be found in the arsenal of any serious user of infrared heat. The Herschel shown right will only appeal to select clientele due to its deep dive scientific nature and cost.

All testing and subsequent reports are also available from Ceramicx.

*The Herschel 3D IR Imaging Machine ( see Heatworks 11 for full details )  
The Herschel is an IR energy mapping instrument, and comprises an ABB robot, a state of the art Infra Red sensing element, and a sophisticated computer processed graphics suite. The instrument was named after Sir Fredrick William Herschel, the discoverer of Infrared Radiation. The Herschel can be used to evaluate and verify heat work solutions in industry including automotive, plastics, composites and aviation and is also indispensable in research and development.*



## SPECIALISED STEATITE COMPONENTS [www.ceramicx.com/specialised-dust-press-components/](http://www.ceramicx.com/specialised-dust-press-components/)

Ceramicx now offers the manufacture of specialist Steatite ceramic dust press components to companies that need quality insulators as part of their product manufacturing. For over twenty years Ceramicx has been shipping components and products to manufacturers in over 65 countries worldwide. Service, confidentiality and world class quality is offered, together with a unique know-how in developing and designing product solutions in Steatite Ceramic where needed.

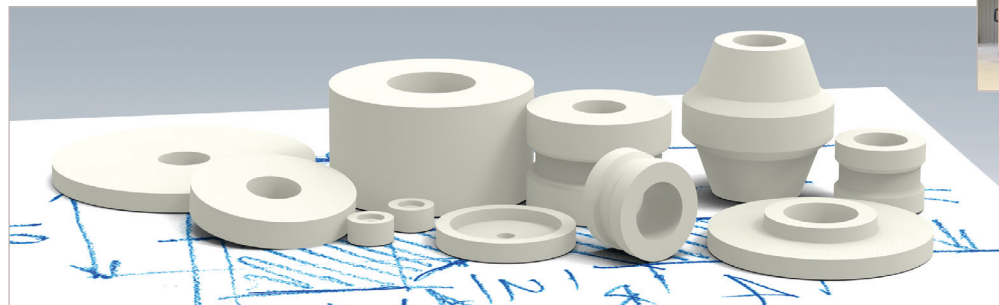

Ceramicx manufactures dust press components on Dorst 20 and 15 tonne presses ( shown above ) and a Dorst 6 tonne press

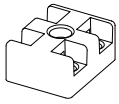

**2P Ceramic Terminal Block**

10 Pack  
no Fittings  
40 x 32 x 20 mm

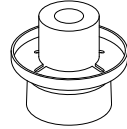
**Ceramic Grommet and Starlock**

**Fastener Set** 100 sets  
per pack - used as an  
Insulator in sheet metal  
with 6mm hole  
21 x 18 x 15 mm

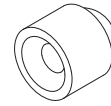
**Ceramic Beads**

per kg  
Loose or Strung  
Ø5 x 6 mm  
4.5 mm to shoulder

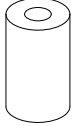
**Ceramic Tubes**

Ø5 x 11 mm

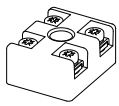
**ACCESSORIES****HIGH TEMPERATURE CONNECTORS**[www.ceramicx.com/high-temperature-connectors/](http://www.ceramicx.com/high-temperature-connectors/)**2P Ceramic Terminal Block**

10 Pack  
Stainless Steel  
Fittings  
40 x 32 x 20 mm

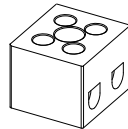
**2P Mini Ceramic Terminal Block**

10 Pack  
Nickel Galvanised Brass  
Inserts, Zinc-plated Steel  
Screws  
21 x 18 x 15 mm

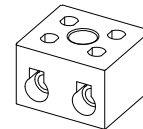
**TB2 Ceramic Terminal Block**

(closed) 10 Pack  
Plated Brass Inserts,  
Nickel Galvanised  
Screws  
34 x 30 x 22 mm

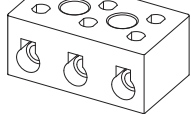
**TB3 Ceramic Terminal Block**

(closed) 10 Pack  
Plated Brass Inserts,  
Nickel Galvanised  
Screws  
51 x 30 x 22mm.

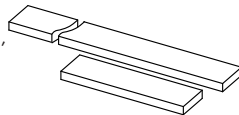
**Stainless Steel Buzz Bar**

used with the ceramic  
terminal block to  
produce a flexible power  
distribution system  
8 x 2 x 1000 mm

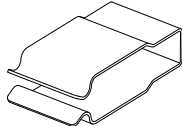
**MOUNTING COMPONENTS**[www.ceramicx.com/mounting-components/](http://www.ceramicx.com/mounting-components/)**Flat Ceramic Base Holder**

For Halogen/Tungsten  
heaters fitted with flat  
ceramic base

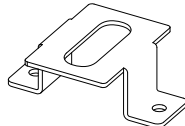
**Mounting Bracket**

For ceramic elements  
72 x 57 x 28 mm.  
slot 42 x 15 mm

**R7s Ceramic Holder**

For Standard Quartz  
Tungsten/Halogen Tubes

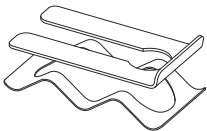
**Steel Wave and Spring set**

Used in the mounting  
and installation of all  
Ceramic elements  
and the Pillared  
Quartz elements

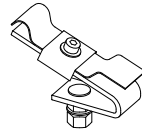
**STQH Holder**

For all types of square  
tube Quartz Heaters  
(STQH)

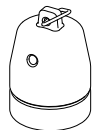
**E27 ACCESSORIES**[www.ceramicx.com/bulb-reflector-and-e27-holder/](http://www.ceramicx.com/bulb-reflector-and-e27-holder/)**E27 Edison Bulb Holder**

High temperature  
porcelain holder used  
with ceramic IR bulbs  
Ø53 x 74 mm

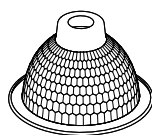
**Ceramic Bulb Reflector**

Highly polished  
reflector for use  
with ceramic IR bulbs  
Ø220 x 110 mm

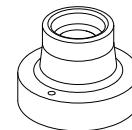
**E27 Bulb Holder with Base**

High temperature  
porcelain holder used  
with ceramic IR bulbs  
Ø78 x 60 mm

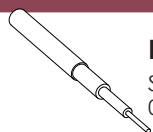
**HIGH TEMPERATURE NPC CABLE**[www.ceramicx.com/high-temperature-npc-cable/](http://www.ceramicx.com/high-temperature-npc-cable/)**High Temperature NPC Cable**

Single Conductor Cable, Flexible Nickel Plated Copper Core, Glass Fibre Insulation, Silicone Coated Fibreglass Braid  
0.75 mm, 1.5mm, 2.5mm, 4.0mm



**Ceramicx joins BPF**

*(The British Plastics Federation)*

Established in 1933 the British Plastics Federation is the most powerful voice in the UK plastic industry with over 400 members, including polymer producers and suppliers, additive manufacturers, recyclers, services providers, end users, plastics processors and machinery manufacturers.

The BPF Annual Dinner has been described as the most prestigious event in the plastics industry calendar. Held in London at the end of October earlier this year, it and provided us with the perfect opportunity to network with suppliers, customers and peers within the industry.



We first met Dr Derek Ford pictured left, when Ceramicx were working with the University of Cambridge's Institute of Marketing. Derek has recently been helping Ceramicx review its business and manufacturing process, with the aim of consolidating recent gains

and developing a ongoing strategic plan for sustainable growth in the future.



*Congratulations to Jan Kaiser on completing his internship*



*Over the last few months Ebru Gizem Yilmaz has been working at Ceramicx as an intern. 'Gizem' recently graduated in Industrial Engineering in Turkey at Sökarya Üniversitesi.*



*Welcome to Cian O'Mahony who has joined the Ceramicx engineering team, where Cian's Electrical skills are being used to the full.*

Talk to us today about your infrared heating needs.



**ceramicx**  
INFRARED FOR INDUSTRY



■ Frank Wilson

Managing Director

frank.wilson@ceramicx.com



■ Dr. Cathal Wilson

Director

cathal.wilson@ceramicx.co.uk

■ Tadhg Whooley

Technical Sales Manager

tadhg.whooley@ceramicx.com

■ Amanda Murphy

Sales and Logistics

amanda.murphy@ceramicx.com

■ Hasan Duman

Sales - Turkey

hasan.duman@ceramicx.com



www.freek.de

Distributor: **Friedr. Freek GmbH**

Address: Sudetenstraße 9, 58708 Menden, Germany

Tel: +49 23 73 - 95 90-0

Fax: +49 2373 9590-30

Email: mail@freek.de



■ Stefan Düllmann

Technical Sales

s.duellmann@freek.de

■ Mareike Blaak

Sales and Marketing

m.blaak@freek.de



www.ceramicx.com.cn

Distributor: **GSAE**

Address: Room 108, 1st floor Building No.1, 20 Bei Dong Lu, Tianhe District, Guangzhou City, 510665, China.

Tel: 020 82310060/020 82329785

Fax: 020 82000073

Email: sales@ceramicx.com.cn



■ Pingqiang Li

Managing Director

ceramicx@126.com

■ Xu Shan

International Business Engineer

weiwei0604@yahoo.com



www.wecointernational.com

Distributor: **Weco International, Inc.**

Address: 901 Tacoma Ct. Clio, MI 48420

Tel: 810 - 686 - 7221, Toll Free: 1-855-IR-2-HEAT

Fax: 810 - 686 - 7564

Email: weco@wecointernational.com



■ Brett Wehner

President/CEO

brettw@wecointernational.com

■ Brett Terbrack

Technical Sales

brett.terbrack@wecointernational.com



## Exhibitions

**Plast Eurasia**  
Istanbul 2015

- **Plast Eurasia 2015** *The 25th International Istanbul Plastics Industry Fair.*  
Tüyap Fair Convention and Congress Center, Büyüçekmece, İstanbul/ Türkiye.  
3 - 6 December 2015.

**Chinaplas® 2016**  
国际橡塑展

- **Chinaplas 2016** *The 30th International Exhibition on plastics and Rubber Industries.*  
Shanghai, New International Expo Centre, Pudong, Shanghai P.R.C. 201204  
25 - 28 April 2016.



- **K 2016** *The Worlds Number 1 Trade Fair for Plastics and Rubber.*  
Messe Düsseldorf, Düsseldorf, Germany.  
19 - 26 October 2016.

- Exhibiting
- Distributor exhibiting
- Visiting

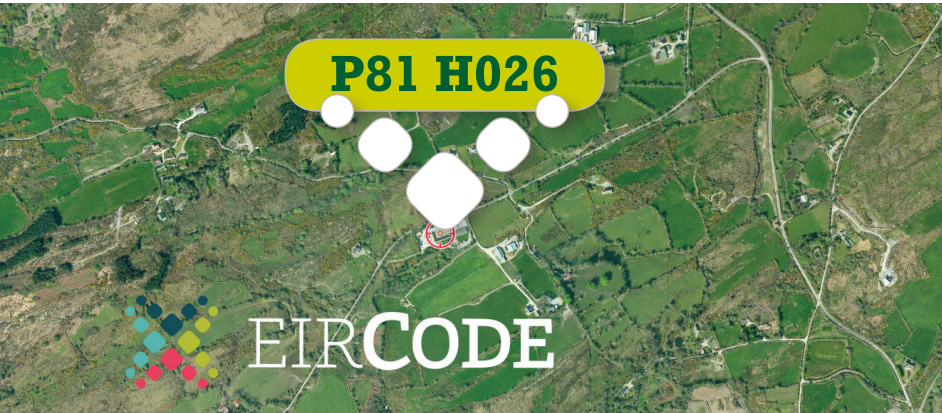

Eircode, Ireland's new postcode system, will enable people and businesses to find every address in Ireland. Over 35% of addresses in Ireland share their address with at least one other property, Eircode has been designed specifically to overcome this problem. Unlike other countries where postcodes define a cluster or group of addresses, a unique Eircode is assigned to each residential and business address. Ceramicx's address now reads -

Gortnagrough, Ballydehob,  
Co. Cork, **P81 H026**, Ireland.



**Ceramicx Ltd.** Gortnagrough, Ballydehob, Co. Cork, P81 HO26, Ireland.  
Tel: +353 28 37510 Fax: +353 28 37509 Email: sales@ceramicx.com [www.ceramicx.com](http://www.ceramicx.com)



**Ceramicx Ltd.** 20 Station Road, Cambridge, CB1 2DJ, U.K.  
Tel: +44 1223 653159 Email: sales@ceramicx.co.uk [www.ceramicx.co.uk](http://www.ceramicx.co.uk)



**Ceramicx Ltd.** Ceramicx İnfrared Teknolojileri Sanayi ve Tic. Ltd. Şti. İkitelli O.S.B. Giyim Sanatkarları İş ve Tic. Mrkz.3. Ada A Blok No:102, Başakşehir, İstanbul / Türkiye.  
Tel: +90 212 549 4839 Mobile: +90 544 237 2649 satis@ceramicx.com [www.ceramicx.com.tr](http://www.ceramicx.com.tr)



**日本七子株式会社**  
**NIPPON HEATER CO., LTD.**

[www.nippon-heater.co.jp](http://www.nippon-heater.co.jp)

Distributor: **Nippon Heater Co., Ltd.**  
Address: 2-13-15, Keihinjima, Ota-ku, Tokyo, Japan.  
Tel: +81 3 3790 3111  
Fax: +81 3 3790 1711  
Email: sales@nippon-heater.co.jp



■ Koshiba Tomonobu  
President  
t-koshiba@nippon-heater.co.jp  
■ Hashimoto Atsushi  
Sales  
a-hashimoto@nippon-heater.co.jp

**elmec**

Heaters & Automation

[www.elmec.in](http://www.elmec.in)

Distributor: **Elmec Heaters and Appliances**  
Address: #103, SIDCO Industrial Estate,  
Ekkattuthangal, Chennai - 600032, India.  
Tel: 0091 - 44 - 22250313 / 22253566  
Mobile: 0091 928 222 7071  
Email: info@elmec.in



■ Mr. Sundarraj  
elmec.sundar@gmail.com  
■ Mr. Selvaraj



**Abso Industries cc**

Distributor: **Abso Industries cc**  
Address: Unit 9, The Square, Prime Park,  
Printers Way, Montague Gardens,  
7447 Cape Town, South Africa.  
Tel: +27 21 552 7303  
Fax: +27 21 552 7304



■ Bobby Bell  
Managing Director  
bobby@absoheating.co.za  
■ Marc Johnson  
Operations Manager

[www.ceramicx.com](http://www.ceramicx.com) | [www.ceramicx.co.uk](http://www.ceramicx.co.uk)

# CHECKOUT

# ceramicx onlineshop

Infrared heating elements direct from the manufacturer

## Ceramic Elements

Trough elements

Hollow Elements

Flat Elements

Ceramic Bulbs

Thermocouples

## Quartz Elements

Quartz Heaters

Single Tube Quartz Heaters

Pillared Quartz Heaters

## Quartz Tungsten / Halogen Elements

Quartz Tungsten Tubes

Quartz Halogen Tubes

Special Tube Orders

## Steatite Press Components



# UK

high temperature  
connectors



# IRL

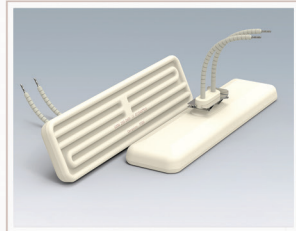

### FULL FLAT ELEMENT HOL...

Available from 250 to 800 Watts  
Dimensions: 245 x 60 ...

VIEW PRODUCT

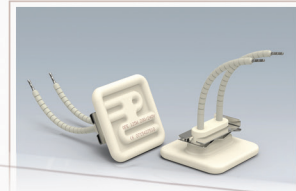

HOME > CERAMIC ELEMENTS > HOLLOW ELEMENTS > FULL FLAT HOLLOW INFRARED HEATING CERAMIC ELEMENT | IR

Full Flat Element Hollow  
Available from 150 to 800 Watts D

#### PRICE

COLOUR

WATTAGE

QUANTITY  +-

ADD TO CART

ADD TO WISH

# shoponline



UK

[www.ceramicx.co.uk](http://www.ceramicx.co.uk)



IRL

[www.ceramicx.com](http://www.ceramicx.com)

For all non standard items contact [sales@ceramicx.com](mailto:sales@ceramicx.com)



## ONLINE INFRARED TRAINING COURSE

The course is divided into four modules that set out the basics of Infrared from an Industry perspective.

Each module will take 60-90 minutes to complete and finishes with a short online test. The modules can be taken online, or taught as part of a classroom course.

Further information can be found inside on pages 8 and 9.

The course is now available online at

[www.ceramicx.com/applications-training/](http://www.ceramicx.com/applications-training/)

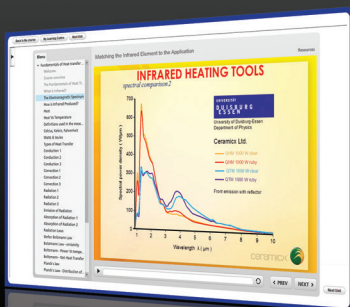

**Module 1**  
Fundamentals of Heat Transfer and Infrared

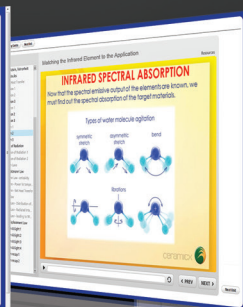

**Module 2**  
Infrared Energy in Process Heat

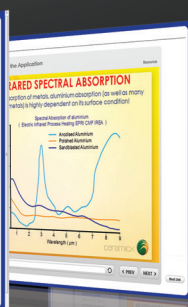

**Module 3**  
Matching the Infrared Element to the Application



**Module 4**  
Control of Infrared